

REV.	DESCRIPTION	DATE	BY

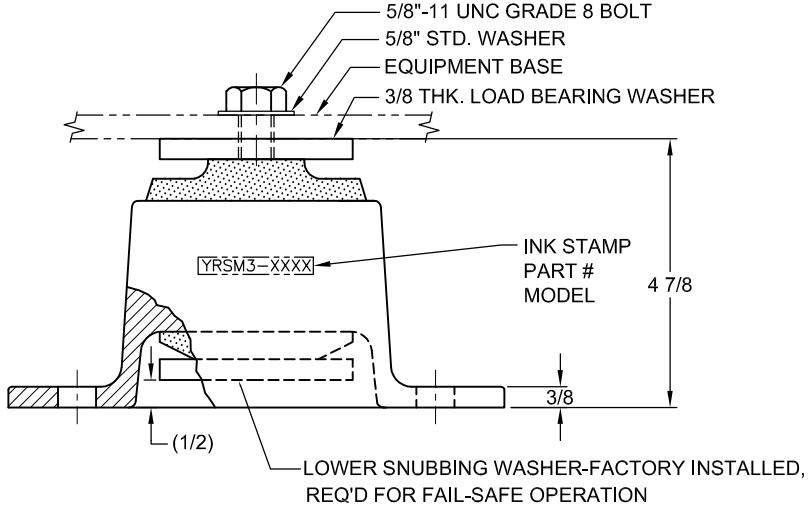

YRSM3 SEISMIC MOUNT			
MODEL	LOAD RANGE (LBS)	DEFLECTION AT LOAD (IN)	MAX. AXIAL DEFL. (LB/IN)
YRSM3-400Z	400	0.15	0.50
YRSM3-700Z	700	0.15	0.50
YRSM3-1000Z	1000	0.15	0.50
YRSM3-1300Z	1300	0.15	0.50
YRSM3-1600Z	1600	0.15	0.50
YRSM3-2300Z	2300	0.15	0.50

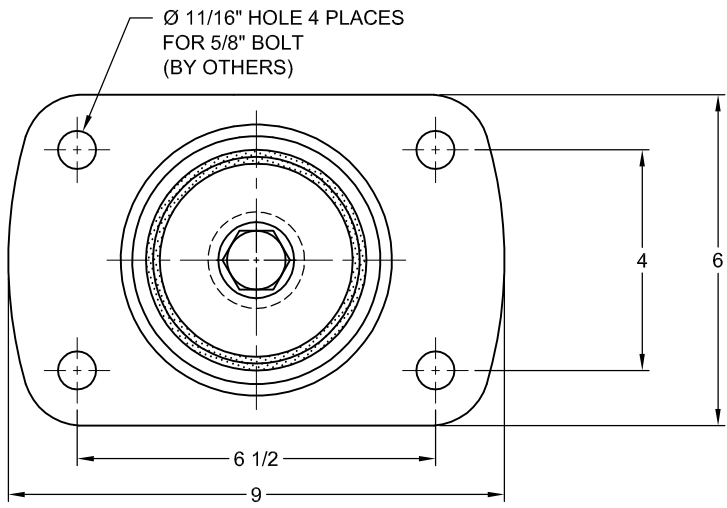

ISOLATOR SELECTIONS	
LOC 1:	LOC 2:
LOC 3:	LOC 4:
LOC 5:	LOC 6:
LOC 7:	LOC 8:
LOC 9:	LOC 10:
LOC 11:	LOC 12:
CUSTOMER EQPT. TAG:	

- NOTES:
1. ALL DIMENSIONS ARE IN INCHES. INTERPRET PER ANSI Y14.
 2. ALL DIMENSIONS ARE NOMINAL AND FOR REFERENCE ONLY.
 3. APPROX. WEIGHT: 14.8 LBS
 4. FINISH: ELECTRO-ZINC PLATED.
 5. MOUNT INCLUDES LOAD BEARING WASHER, 5/8"-11 UNC GRADE 8 BOLT AND 5/8" STD. WASHER.
 6. MOLDED METAL AND ELASTOMER MOUNT DESIGNED FOR FAIL-SAFE "CAPTIVE", "MOBILE" OR "SEISMIC" APPLICATIONS. LOWER SNUBBING WASHERS ARE FACTORY INSTALLED FOR A FAIL SAFE OPERATION. CONSULT VMC FOR APPLICABILITY AND LIMITS.

NOTE: MATERIAL SHOWN IS FOR (1) SET.

OTHER MATERIALS, COMPOUNDS, OR FINISHES WITH EQUAL OR SUPERIOR PROPERTIES MAY BE SUBSTITUTED AS THEY BECOME AVAILABLE.

CERTIFIED FOR:

JOB NAME: _____

CUSTOMER : _____

CUSTOMER P.O.: _____

SALES ORDER: _____

**MODEL YRSM3 400-2300 LBS.
SEISMIC MOUNT
ELECTRO ZINC PLATED**

THE VMC GROUP
The Power of Together
Bloomington, NJ 07403
Houston, TX 77041

SCALE: NONE

SHEET: _____

DRAWING NO.: _____

REVISION _____