

REV.	DESCRIPTION	DATE	BY

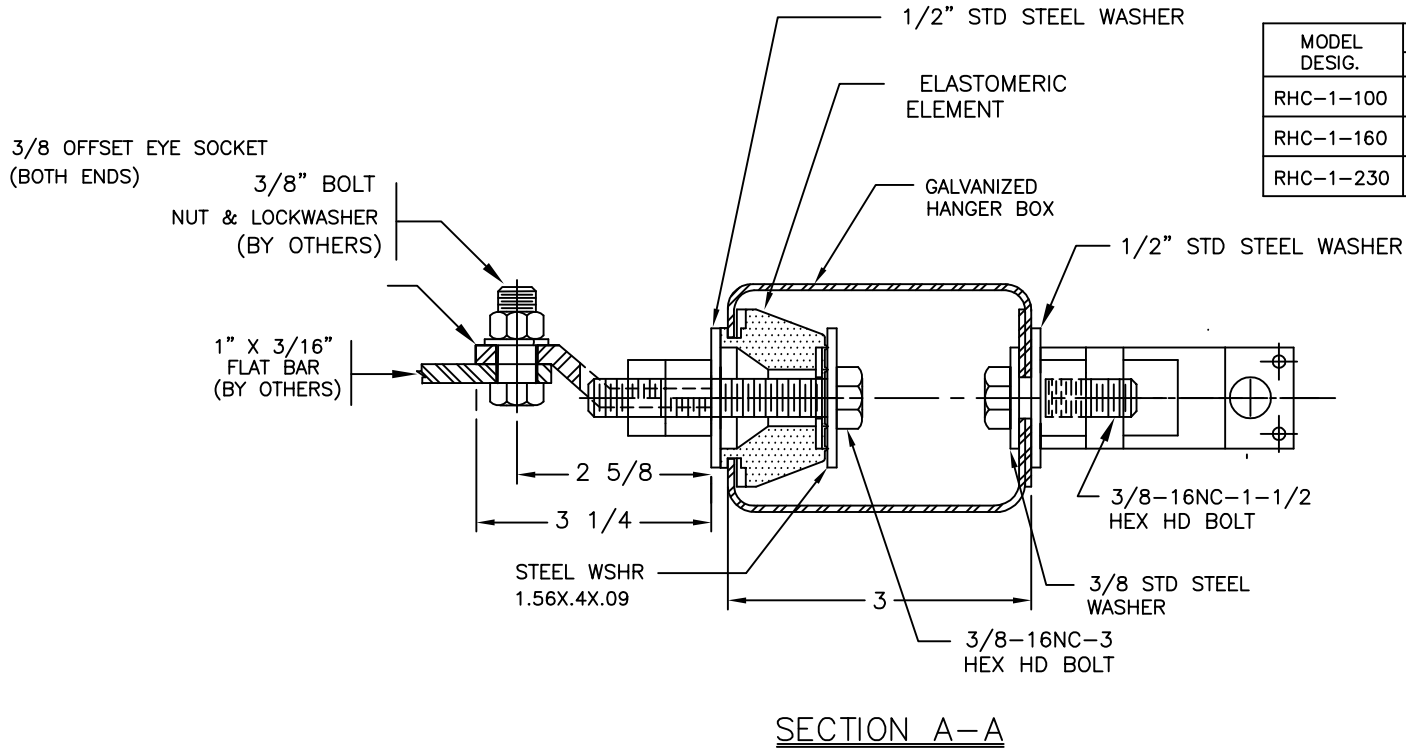

MODEL DESIG.	MAX. LOAD		DEFLECTION		COLOR CODE
	(lbs)	(kg)	(ins)	(mm)	
RHC-1-100	100	45.5	.25	(6.3)	WHITE
RHC-1-160	160	72.7	.25	(6.3)	GREEN
RHC-1-230	230	104.5	.25	(6.3)	RED

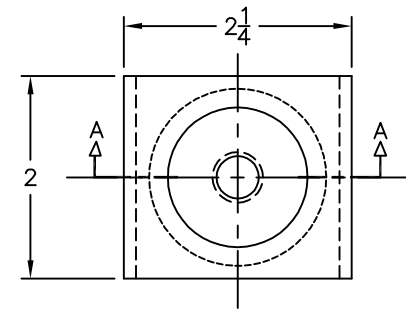

NOTES:

1. ALL DIMENSIONS IN INCHES. INTERPRET PER ANSI Y14.
2. RUBBER IS BRIDGE BEARING, NEOPRENE OR EQUIVALENT.

OTHER MATERIALS, COMPOUNDS, OR FINISHES WITH EQUAL OR SUPERIOR PROPERTIES MAY BE SUBSTITUTED AS THEY BECOME AVAILABLE.

CERTIFIED FOR:

JOB NAME: _____
 CUSTOMER : _____
 CUSTOMER P.O.: _____
 SALES ORDER: _____

**MODEL RHC 100-230 LBS. ELASTOMERIC
 CEILING ISOLATED HANGER
 WITH OFFSET EYELET
 0.25 DEFLECTION**



THE VMC GROUP
The Power of Together
 Bloomingdale, NJ 07403
 Houston, TX 77041

SCALE :

NONE

SHEET:



DRAWING NO.:

REVISION