

REV.	DESCRIPTION	DATE	BY

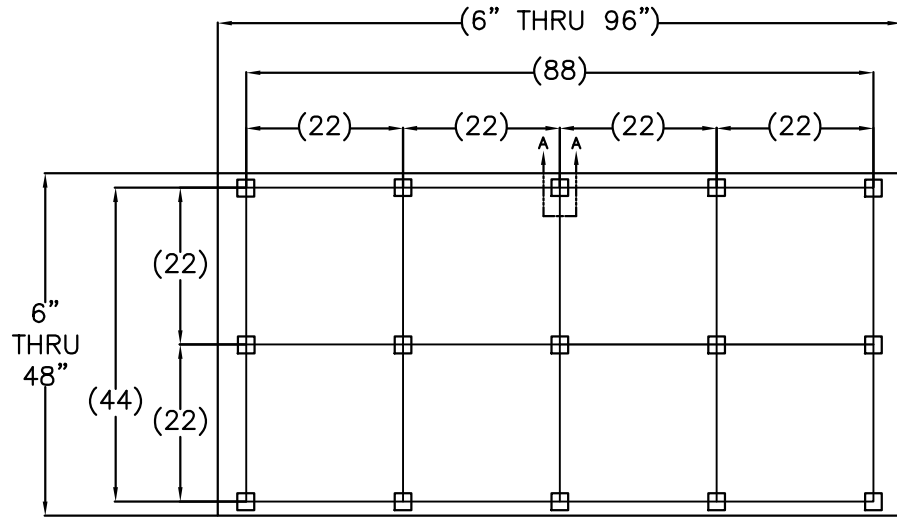

4 x 8 PANEL LAYOUT SHOWN

MODEL NUMBER	RATED LOAD	HEIGHT	LENGTH	WIDTH	APP. WT.	COATING COLOR
QFFG 222-400	400 LBS.	2.0-IN.	2.0-IN.	2.0-IN.	.12 LBS.	BLACK
QFFG 233-900	900 LBS.	2.0-IN.	3.0-IN.	3.0-IN.	.27 LBS.	BLACK

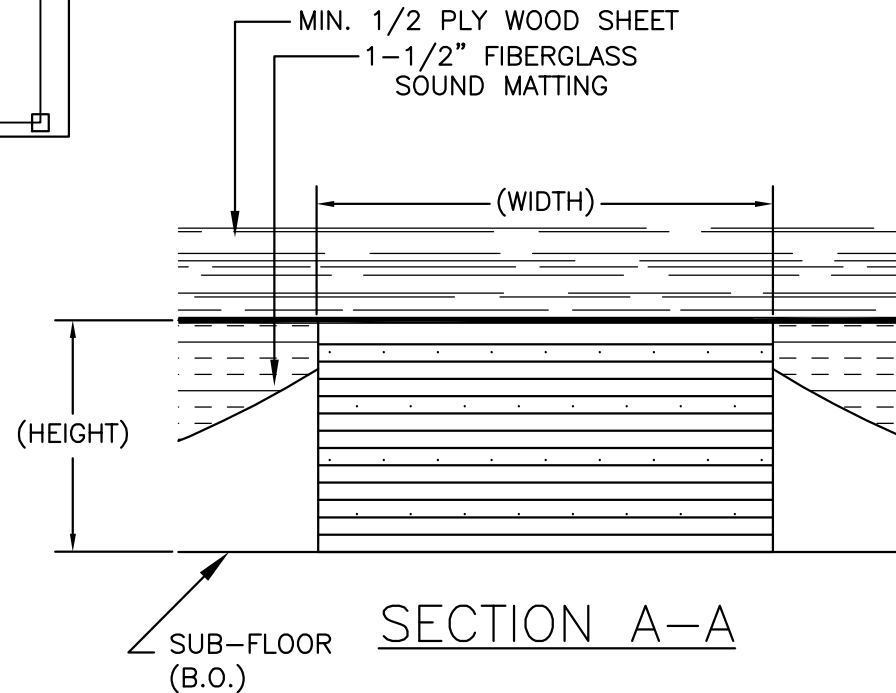

NOTE:

1. 4' X 8' IS STANDARD PANEL SIZE.
2. PANEL SIZE VARIES BASED ON CUSTOMERS REQUIREMENTS.
3. DIMENSIONS MAY VARY ON CUSTOMERS REQUIREMENTS.
4. ALL DIMENSIONS IN INCHES. INTERPRET PER ANSI Y14.

(B.O.)= BY OTHER, NOT VMC

OTHER MATERIALS, COMPOUNDS, OR FINISHES WITH EQUAL OR SUPERIOR PROPERTIES MAY BE SUBSTITUTED AS THEY BECOME AVAILABLE.

CERTIFIED FOR:

JOB NAME: _____
 CUSTOMER : _____
 CUSTOMER P.O.: _____
 SALES ORDER: _____

**MODEL QFFG 400-900 LBS.
 ISOLATED FLOATING FLOOR WITH
 FIBERGLASS BLOCK**



THE VMC GROUP
The Power of Together
 Bloomingdale, NJ 07403
 Houston, TX 77041

SCALE :

NONE

SHEET:



DRAWING NO.:

REVISION

REV.	DESCRIPTION	DATE	BY

INSTRUCTIONS:

1. SUB FLOOR TO BE LEVEL, SMOOTH & CLEAR OF CLEAR DEBRIS(B.O.)
2. INSTALL PERIMETER ISOLATION AROUND THE AREA THE PANEL WILL BE PLACED (B.O.)
3. PLACE QFFN PANEL SNUGLY AGAINST EACH OTHER PER LAYOUT.
4. INSTALL WATER PROOFING AND OVERLAP 1' (B.O.)
5. INSTALL REBAR IF NEEDED AS PART OF PROJECT REQUIREMENT.(B.O)
6. POUR CONCRETE ON TO ALL PANELS. (B.O)
7. INSTALL MASTIC SEAL ON TOP OF THE PERIMETER BOARDS.(B.O)
8. FINISHED: UNLESS FINISH FLOOR IS REQUIRED.
9. SLAB DESIGN & CONSTRUCTION IS BY OTHERS NOT VMC

NOTE:

B.O. = BY OTHERS NOT BY VMC

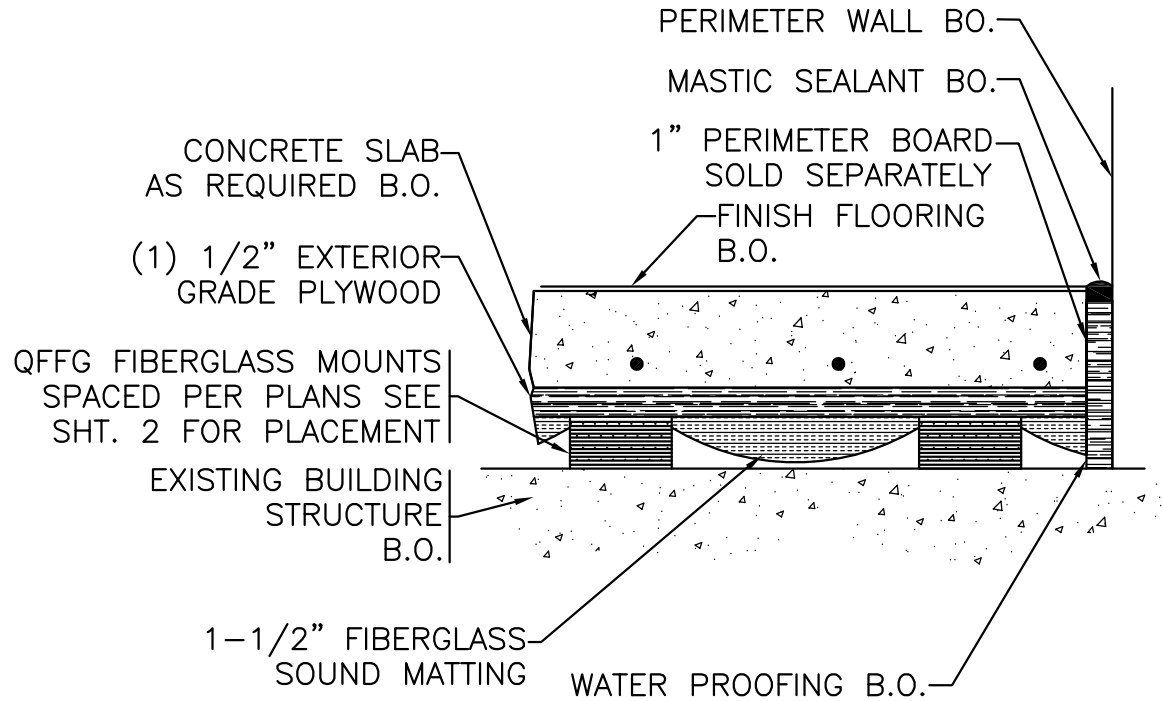

QFFG FLOATING FLOOR
 INSTALLATION DETAILS

OTHER MATERIALS, COMPOUNDS, OR FINISHES WITH EQUAL OR SUPERIOR PROPERTIES MAY BE SUBSTITUTED AS THEY BECOME AVAILABLE.

CERTIFIED FOR:

JOB NAME: _____
 CUSTOMER : _____
 CUSTOMER P.O.: _____
 SALES ORDER: _____

**MODEL QFFG 400-900 LBS.
 ISOLATED FLOATING FLOOR WITH
 FIBERGLASS BLOCK**



THE VMC GROUP
The Power of Together
 Bloomingdale, NJ 07403
 Houston, TX 77041

SCALE : NONE	Member VISCMA
SHEET:	
DRAWING NO.:	REVISION