

REV.	DESCRIPTION	DATE	BY

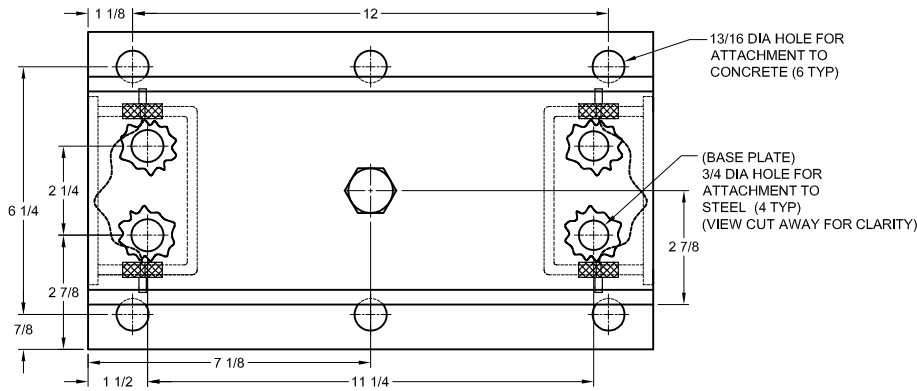

MODEL M2SSH-1E SEISMICALLY RESTRAINED VIBRATION ISOLATOR FOR 1" DEFLECTION				
SEISMIC MOUNT SIZE	RATED LOAD (LBS)	RATED DEFLECTION (IN)	SPRING RATE (LBS/IN)	COLOR CODE
M2SSH-1E-1650N	1650	1.07	1538	RED/DK. BLUE
M2SSH-1E-2000	2000	1.00	2000	TAN
M2SSH-1E-3400N	3400	1.10	3100	PINK/DK. BLUE
M2SSH-1E-4000	4000	1.11	3600	WHITE
M2SSH-1E-5150N	5150	1.11	4626	WHITE/DK. PURPLE
M2SSH-1E-5980N	5980	1.11	5364	WHITE/DK. GREEN
M2SSH-1E-6500N	6500	1.04	6250	WHITE/GRAY

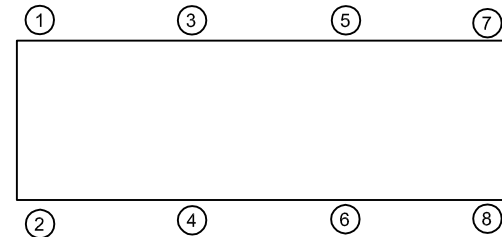
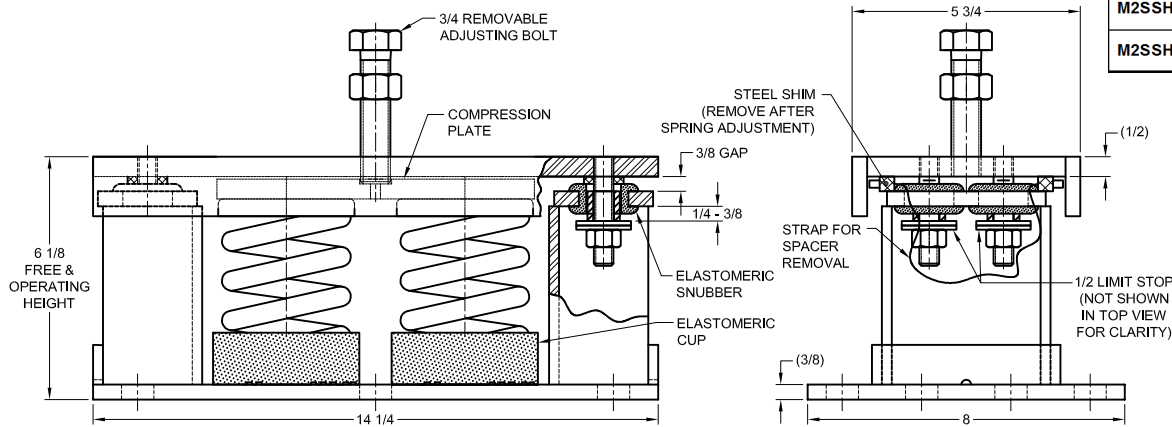

- NOTES:
1. ALL DIMENSIONS ARE IN INCHES, INTERPRET PER ANSI Y14.
 2. STANDARD FINISH: HOUSING - POWDER COAT (COLOR:BLACK), SPRING - POWDER COAT (COLOR: SEE TABLE), HARDWARE ZINC-ELECTROPLATE.
 3. EQUIPMENT MUST BE BOLTED OR WELDED TO THE TOP AND BOTTOM PLATE TO MEET ALLOWABLE SEISMIC RATINGS.
 4. ALL SPRINGS ARE DESIGNED FOR 50% OVERLOAD CAPACITY.
 5. REFER TO SHEET 2 OF 2 FOR INSTALLATION INSTRUCTIONS.

ISOLATOR SELECTIONS	
LOC 1:	LOC 2:
LOC 3:	LOC 4:
LOC 5:	LOC 6:
LOC 7:	LOC 8:
CUSTOMER EQP'T. TAG:	

NOTE: MATERIAL SHOWN IS FOR (1) SET.

OTHER MATERIALS, COMPOUNDS, OR FINISHES WITH EQUAL OR SUPERIOR PROPERTIES MAY BE SUBSTITUTED AS THEY BECOME AVAILABLE.

CERTIFIED FOR:

JOB NAME: _____

CUSTOMER : _____

CUSTOMER P.O.: _____

SALES ORDER: _____

**MODEL M2SSH-1E 1650-6500 LBS.
VIBRATION ISOLATOR
WITH INTEGRAL SEISMIC RESTRAINT
AND EXTERNAL ADJUSTMENT
1 INCH DEFLECTION**



THE VMC GROUP
The Power of Together
Bloomington, NJ 07403
Houston, TX 77041

SCALE:

NONE

SHEET:



DRAWING NO.:

REVISION

REV.	DESCRIPTION	DATE	BY

- 1. READ INSTRUCTIONS IN THEIR ENTIRETY BEFORE BEGINNING INSTALLATION.**
- ISOLATORS ARE SHIPPED FULLY ASSEMBLED AND ARE TO BE POSITIONED IN ACCORDANCE WITH THE SUBMITTAL DRAWINGS OR AS OTHERWISE RECOMMENDED.
- SET ISOLATORS ON FLOOR, HOUSEKEEPING PAD, OR SUB-BASE, ENSURING THAT ALL ISOLATOR CENTERLINES MATCH THE EQUIPMENT MOUNTING HOLES. THE VMC GROUP RECOMMENDS THAT THE ISOLATOR BASE PLATES ("B") BE INSTALLED ON A LEVEL SURFACE. SHIM OR GROUT AS REQUIRED, LEVELING ALL ISOLATOR BASE PLATES AT THE SAME ELEVATION (1/4-INCH MAXIMUM DIFFERENCE CAN BE TOLERATED).
- ANCHOR ALL ISOLATORS TO THE FLOOR, HOUSEKEEPING PAD, OR SUB-BASE USING THRU HOLES ("C") FOR CONCRETE OR ("D") FOR STEEL AS REQUIRED. USE ANCHORS MEETING THE DESIGN REQUIREMENTS SPECIFIED ON SHEET 1 OF 2. WELDING TO STEEL IS PERMITTED PROVIDING THE WELD ACHIEVES THE REQUIRED STRENGTH.
- ISOLATORS ARE SHIPPED TO THE JOBSITE WITH (4) REMOVABLE SPACER SHIMS ("E") BETWEEN THE TOP PLATE AND THE HOUSING. THESE SHIMS **MUST** BE IN PLACE WHEN THE EQUIPMENT IS POSITIONED OVER THE ISOLATORS.
- WITH ALL SHIMS ("E") IN PLACE, REMOVE ADJUSTING BOLT "G", AND SET ASIDE. KEEP THE NUT "H" SCREWED ONTO THE ADJUSTING BOLT. PLACE THE MACHINE OR EQUIPMENT ONTO TOP PLATE "A", ALIGNING THE EQUIPMENT MOUNTING HOLE WITH THE TAPPED HOLE IN THE TOP PLATE. REATTACH THE ADJUSTING BOLT BY BOLTING THROUGH THE EQUIPMENT MOUNTING HOLE INTO THE TAPPED HOLE OF THE (**Cont.**)

6. (Cont.)

ISOLATOR. TURN THE ADJUSTING BOLT UNTIL IT STARTS TO COMPRESS THE SPRING. LEAVE NUT "H" AT THE TOP OF THE ADJUSTING BOLT, LEAVING ROOM FOR ADJUSTING THE ISOLATOR PER STEP 9.

7. THE ADJUSTMENT PROCESS CAN ONLY BEGIN AFTER THE EQUIPMENT OR MACHINE IS AT ITS FULL OPERATING WEIGHT.

- BACK OFF EACH OF THE (2) OR (4) LIMIT STOP LOCKNUTS ("F") PER ISOLATOR 1/4- TO 3/8-INCH.
- ADJUST EACH ISOLATOR IN SEQUENCE BY TURNING ADJUSTING BOLT(S) "G" ONE FULL CLOCKWISE TURN AT A TIME. REPEAT THIS PROCEDURE ON ALL ISOLATORS, ONE AT A TIME. CHECK THE LIMIT STOP LOCKNUTS ("F") PERIODICALLY TO ENSURE THAT CLEARANCE BETWEEN THE WASHER AND RUBBER GROMMET IS MAINTAINED. STOP ADJUSTMENT OF AN ISOLATOR ONLY WHEN THE TOP PLATE ("A") HAS RISEN JUST ABOVE THE SHIM ("E").
- REMOVE ALL SPACER SHIMS ("E").
- FINE ADJUST ISOLATORS TO LEVEL EQUIPMENT.
- ADJUST ALL LIMIT STOP LOCKNUTS ("F") PER ISOLATOR TO OBTAIN 3/8-INCH GAP. THE LIMIT STOP NUTS MUST BE KEPT AT THIS 3/8-INCH GAP TO ENSURE UNIFORM BOLT LOADING DURING UPLIFT (AS IN THE CASE WHEN A COOLING TOWER IS DRAINED).
- INSTALLATION IS COMPLETE.

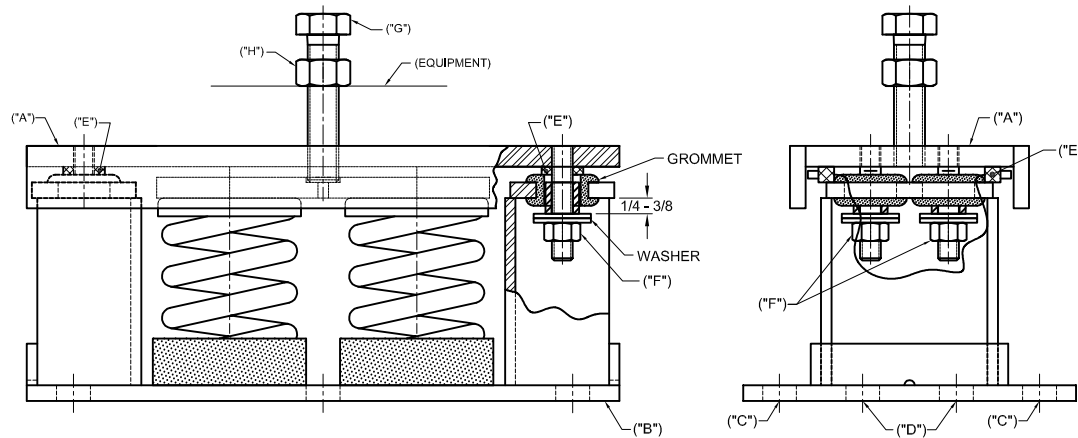

OTHER MATERIALS, COMPOUNDS, OR FINISHES WITH EQUAL OR SUPERIOR PROPERTIES MAY BE SUBSTITUTED AS THEY BECOME AVAILABLE.

CERTIFIED FOR:

JOB NAME: _____
 CUSTOMER : _____
 CUSTOMER P.O.: _____
 SALES ORDER: _____

**MODEL M2SSH-1E 1650-6500 LBS.
 VIBRATION ISOLATOR
 WITH INTEGRAL SEISMIC RESTRAINT
 AND EXTERNAL ADJUSTMENT
 1 INCH DEFLECTION**



THE VMC GROUP
The Power of Together
 Bloomingdale, NJ 07403
 Houston, TX 77041

SCALE:

NONE

SHEET:



DRAWING NO.:

REVISION