

| REV. | DESCRIPTION | DATE | BY |
|------|-------------|------|----|
| | | | |

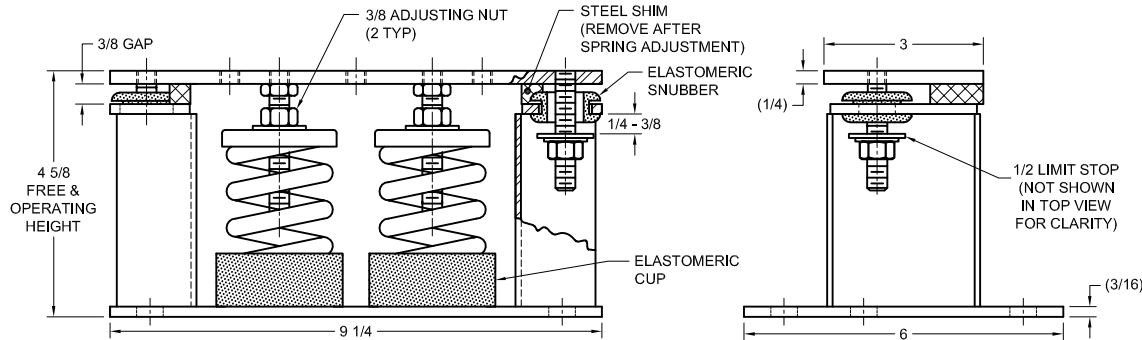

| MODEL M2S-1C SEISMICALLY RESTRAINED VIBRATION ISOLATOR FOR 1" DEFLECTION | | | | |
|--|------------------|-----------------------|----------------------|---------------|
| SEISMIC MOUNT SIZE | RATED LOAD (LBS) | RATED DEFLECTION (IN) | SPRING RATE (LBS/IN) | COLOR CODE |
| M2S-1C-500 | 500 | 0.83 | 602 | BLACK |
| M2S-1C-600 | 600 | 0.75 | 800 | DK YELLOW |
| M2S-1C-740 | 740 | 0.75 | 987 | YELLOW |
| M2S-1C-1040N | 1040 | 0.75 | 1396 | YELLOW/ GREEN |

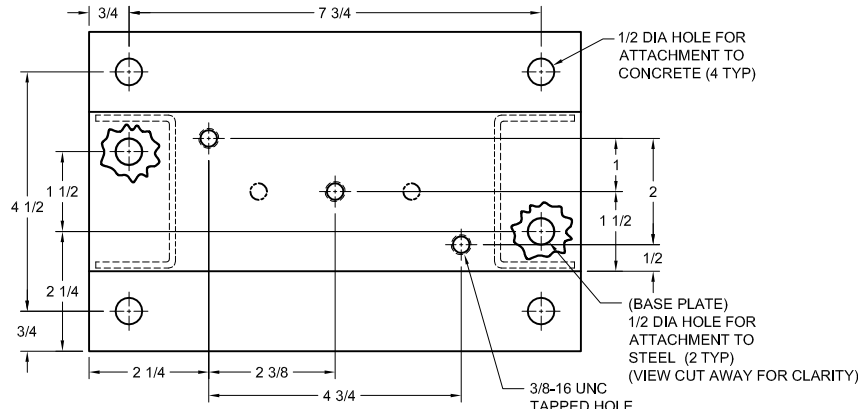
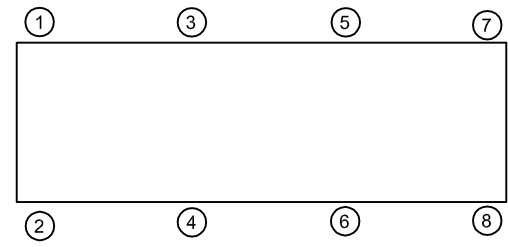

- NOTES:
1. ALL DIMENSIONS ARE IN INCHES, INTERPRET PER ANSI Y14.
 2. STANDARD FINISH: HOUSING - POWDER COAT (COLOR:BLACK), SPRING - POWDER COAT (COLOR: SEE TABLE), HARDWARE ZINC-ELECTROPLATE.
 3. EQUIPMENT MUST BE BOLTED OR WELDED TO THE TOP PLATE TO MEET ALLOWABLE SEISMIC RATINGS.
 4. ISOLATOR BASE PLATE MUST BE ANCHORED TO CONCRETE WITH (4) 3/8 DIA ANCHORS.
 5. ALL SPRINGS ARE DESIGNED FOR 50% OVERLOAD CAPACITY.
 6. REFER TO SHEET 2 OF 2 FOR INSTALLATION INSTRUCTIONS.
 7. RATED DEFLECTIONS ARE WITHIN 25% OF NOMINAL. HIGHER DEFLECTIONS ARE ALLOWED IF THEY MEET SPECIFICATIONS.

| ISOLATOR SELECTIONS | |
|----------------------|--------|
| LOC 1: | LOC 2: |
| LOC 3: | LOC 4: |
| LOC 5: | LOC 6: |
| LOC 7: | LOC 8: |
| CUSTOMER EQP'T. TAG: | |

NOTE: MATERIAL SHOWN IS FOR (1) SET.

OTHER MATERIALS, COMPOUNDS, OR FINISHES WITH EQUAL OR SUPERIOR PROPERTIES MAY BE SUBSTITUTED AS THEY BECOME AVAILABLE.

CERTIFIED FOR:

JOB NAME: _____

CUSTOMER: _____

CUSTOMER P.O.: _____

SALES ORDER: _____

MODEL M2S-1C 500-1040 LBS.VIBRATION ISOLATOR WITH INTEGRAL SEISMIC RESTRAINT AND INTERNAL ADJUSTMENT FOR 1 INCH DEFLECTION



| | | |
|--------------|--------|----------|
| SCALE: | NONE | |
| SHEET: | 1 OF 2 | |
| DRAWING NO.: | | REVISION |

| REV. | DESCRIPTION | DATE | BY |
|------|-------------|------|----|
| | | | |

1. READ INSTRUCTIONS IN THEIR ENTIRETY BEFORE BEGINNING INSTALLATION.



- ISOLATORS ARE SHIPPED FULLY ASSEMBLED AND ARE TO BE POSITIONED IN ACCORDANCE WITH THE SUBMITTAL DRAWINGS OR AS OTHERWISE RECOMMENDED.
- SET ISOLATORS ON FLOOR, HOUSEKEEPING PAD, OR SUB-BASE, ENSURING THAT ALL ISOLATOR CENTERLINES MATCH THE EQUIPMENT MOUNTING HOLES. THE VMC GROUP RECOMMENDS THAT THE ISOLATOR BASE PLATES ("B") BE INSTALLED ON A LEVEL SURFACE. SHIM OR GROUT AS REQUIRED, LEVELING ALL ISOLATOR BASE PLATES AT THE SAME ELEVATION (1/4-INCH MAXIMUM DIFFERENCE CAN BE TOLERATED).
- ANCHOR ALL ISOLATORS TO THE FLOOR, HOUSEKEEPING PAD, OR SUB-BASE USING THRU HOLES ("C") FOR CONCRETE OR ("D") FOR STEEL AS REQUIRED. USE ANCHORS MEETING THE DESIGN REQUIREMENTS SPECIFIED ON SHEET 1 OF 2. WELDING TO STEEL IS PERMITTED PROVIDING THE WELD ACHIEVES THE REQUIRED STRENGTH.
- ISOLATORS ARE SHIPPED TO THE JOBSITE WITH (2) REMOVABLE SPACER SHIMS ("E") BETWEEN THE TOP PLATE AND THE HOUSING. THESE SHIMS **MUST** BE IN PLACE WHEN THE EQUIPMENT IS POSITIONED OVER THE ISOLATORS.
- WITH ALL SHIMS ("E") IN PLACE, PLACE THE MACHINE OR EQUIPMENT ONTO TOP PLATE ("A") OF THE ISOLATORS. BOLT EQUIPMENT SECURELY TO THE ISOLATORS USING MINIMUM ASTM A325 SAE GR. 5) HIGH-STRENGTH BOLTS, MEETING THE REQUIREMENTS (IF ANY) SPECIFIED ON SHEET 1 OF 2. WELDING IS PERMITTED PROVIDING THE WELD ACHIEVES THE REQUIRED STRENGTH.

7. THE ADJUSTMENT PROCESS CAN ONLY BEGIN AFTER THE EQUIPMENT OR MACHINE IS AT ITS FULL OPERATING WEIGHT.

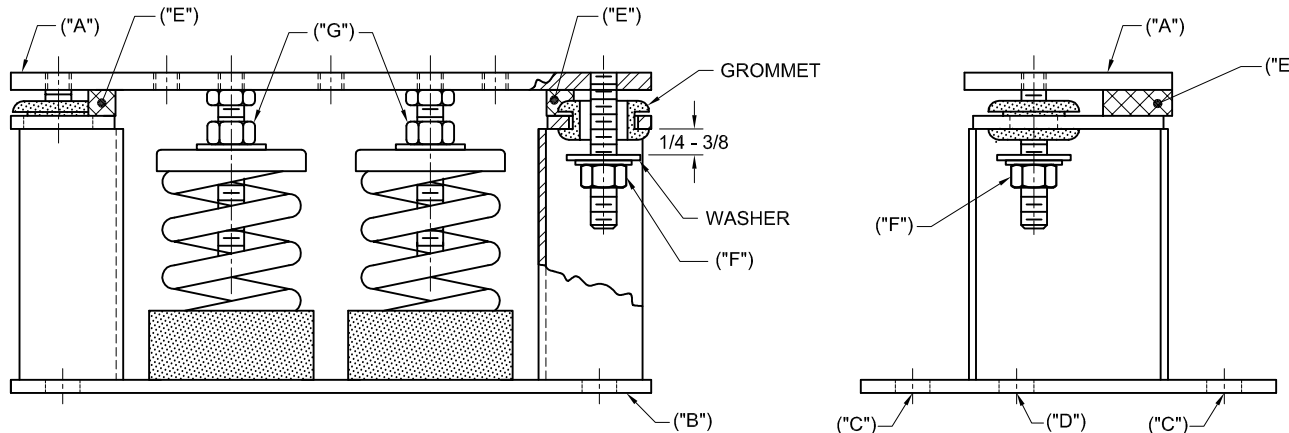
- BACK OFF EACH OF THE (2) OR (4) LIMIT STOP LOCKNUTS ("F") PER ISOLATOR 1/4- TO 3/8-INCH.
- ADJUST EACH ISOLATOR IN SEQUENCE BY TURNING ADJUSTING NUT(S) "G" ONE FULL CLOCKWISE TURN AT A TIME. REPEAT THIS PROCEDURE ON ALL ISOLATORS, ONE AT A TIME. CHECK THE LIMIT STOP LOCKNUTS ("F") PERIODICALLY TO ENSURE THAT CLEARANCE BETWEEN THE WASHER AND RUBBER GROMMET IS MAINTAINED. STOP ADJUSTMENT OF AN ISOLATOR ONLY WHEN THE TOP PLATE ("A") HAS RISEN JUST ABOVE THE SHIM ("E").
- REMOVE ALL SPACER SHIMS ("E").
- FINE ADJUST ISOLATORS TO LEVEL EQUIPMENT.
- ADJUST ALL LIMIT STOP LOCKNUTS ("F") PER ISOLATOR TO OBTAIN 3/8-INCH GAP. THE LIMIT STOP NUTS MUST BE KEPT AT THIS 3/8-INCH GAP TO ENSURE UNIFORM BOLT LOADING DURING UPLIFT (AS IN THE CASE WHEN A COOLING TOWER IS DRAINED).
- INSTALLATION IS COMPLETE.



OTHER MATERIALS, COMPOUNDS, OR FINISHES WITH EQUAL OR SUPERIOR PROPERTIES MAY BE SUBSTITUTED AS THEY BECOME AVAILABLE.

| | | | | |
|---|--|--|---|---|
| <p>CERTIFIED FOR:</p> <p>JOB NAME: _____</p> <p>CUSTOMER : _____</p> <p>CUSTOMER P.O.: _____</p> <p>SALES ORDER: _____</p> | <p>MODEL M2S-1C 500-1040 LBS.VIBRATION ISOLATOR WITH INTEGRAL SEISMIC RESTRAINT AND INTERNAL ADJUSTMENT FOR 1 INCH DEFLECTION</p> |  <p>THE VMC GROUP The Power of Together Bloomingdale, NJ 07403 Houston, TX 77041</p> | <p>SCALE :</p> <p style="text-align: center;">NONE</p> |  |
| | | | <p>SHEET:</p> <p style="text-align: center;">2 OF 2</p> | |