

REV.	DESCRIPTION	DATE	BY

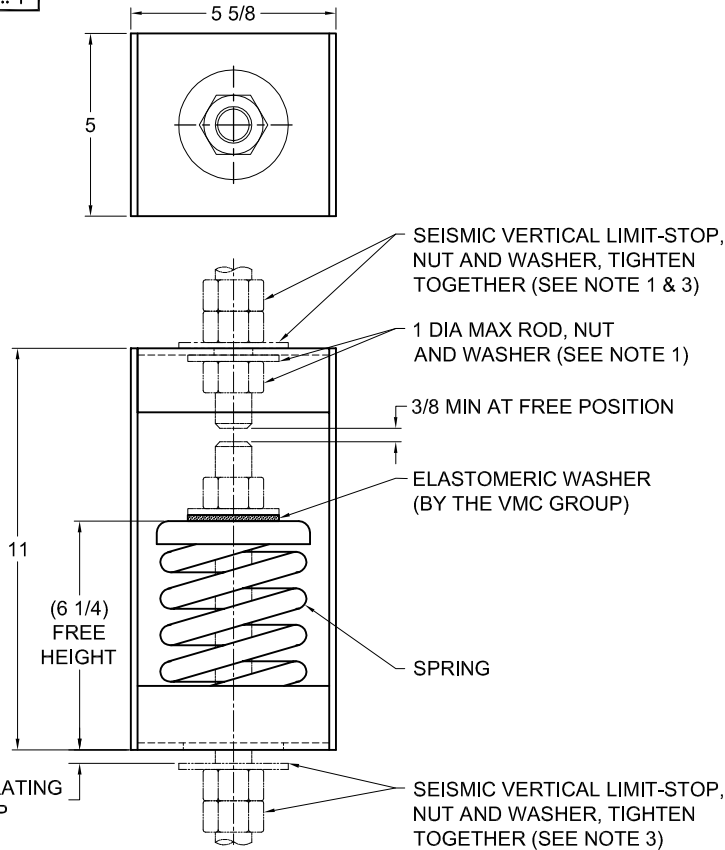

TYPE HS-2E PRE-COMPRESSED SPRING HANGERS FOR 2" NOMINAL DEFLECTION				
HANGER	RATED LOAD (LBS)	DEFLECTION (IN)	SPRING RATE (LB/IN)	SPRING COLOR CODE
HS-2E-80PR	80	2.00	40	BLACK
HS-2E-150PR	150	2.00	75	GREEN
HS-2E-300PR	300	2.00	150	DK YELLOW
HS-2E-500PR	500	2.00	250	BLUE
HS-2E-776N ¹ PR	776	2.00	388	BLUE/BLACK
HS-2E-1000PR	1000	2.00	500	TAN
HS-2E-1400PR	1400	1.87	749	RED
HS-2E-1600N ¹ PR	1600	2.13	750	TAN/RED
HS-2E-1800PR	1800	1.71	1053	DK GRAY
HS-2E-2050PR	2050	1.64	1250	DK BLUE
HS-2E-2250N ¹ PR	2250	1.62	1389	DK BLUE/BLACK
HS-2E-2460N ¹ PR	2460	1.64	1500	DK BLUE/RED
HS-2E-2700N ¹ PR	2700	1.64	1646	DK BLUE/ DK GREEN

NOTES:

1. TWO NESTED SPRINGS YIELD THIS LOAD. THE COLOR CODE INDICATED IS FOR OUTER SPRING/ INNER SPRING.

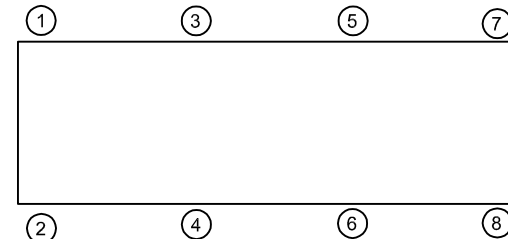

NOTES:

- HANGER RODS, NUTS AND WASHERS, AS SHOWN, NOT BY THE VMC GROUP. INSTALL WASHER .16 THK. MIN. X 3 O.D. MIN WITH REQUIRED INSIDE DIAMETER TO ACCOMMODATE ROD SIZE IN USE. THIS CAN BE ACCOMPLISHED BY USING A SINGLE WASHER OR BY STACKING NOT MORE THAN TWO WASHERS.
- STANDARD FINISH: HANGER BOX - PAINTED, POWDER COATED OR GALVANIZED STEEL, SPRING - POWDER COAT.
- SEISMIC VERTICAL LIMIT-STOP REQUIRED FOR SEISMIC APPLICATIONS.
- ALL DIMENSIONS IN INCHES. INTERPRET PER ANSI Y14.
- ALL DIMENSIONS ARE FOR REFERENCE, DIMENSIONS SHOWN AS NOMINAL.
- ALL SPRINGS ARE DESIGNED WITH MINIMUM 50% OVER-TRAVEL.
- HANGER BOXES ARE AVAILABLE PRE-COMPRESSED UP TO THEIR DESIGNATED MAX. LOAD. PERCENTAGE OF PRE-COMPRESSION TO BE DETERMINED BY ENGINEERED APPLICATION OR AS REQUESTED BY CUSTOMER. CONSULT FACTORY FOR POSSIBLE ADDITIONAL PARAMETERS AND OR LIMITATIONS.
- RATED DEFLECTIONS ARE WITHIN 25% OF NOMINAL. HIGHER DEFLECTIONS ARE ALLOWED IF THEY MEET SPECIFICATIONS.

ISOLATOR SELECTIONS

LOC 1:	LOC 2:
LOC 3:	LOC 4:
LOC 5:	LOC 6:
LOC 7:	LOC 8:
CUSTOMER EQP'T. TAG:	

NOTE: MATERIAL SHOWN IS FOR (1) SET.

OTHER MATERIALS, COMPOUNDS, OR FINISHES WITH EQUAL OR SUPERIOR PROPERTIES MAY BE SUBSTITUTED AS THEY BECOME AVAILABLE.

CERTIFIED FOR:

JOB NAME: _____
 CUSTOMER : _____
 CUSTOMER P.O.: _____
 SALES ORDER: _____

**MODEL HS-2E 80-2700 LBS.
 PRE-COMPRESSED SPRING HANGERS
 2 INCH DEFLECTION**



THE VMC GROUP
The Power of Together
 Bloomingdale, NJ 07403
 Houston, TX 77041

SCALE :

NONE

SHEET:



DRAWING NO.:

REVISION