

REV.	DESCRIPTION	DATE	BY

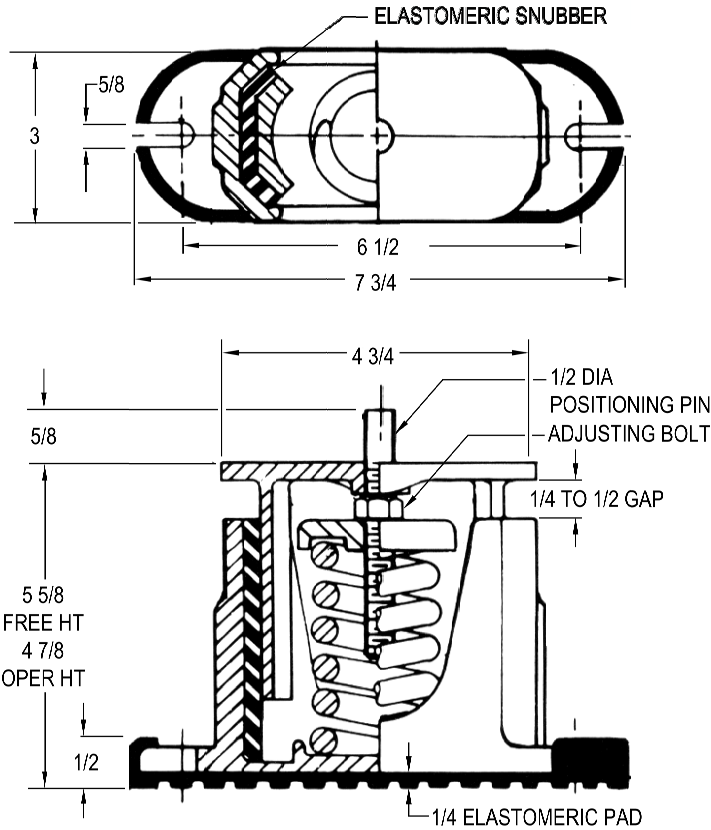

TYPE CP-1D CAST IRON SPRING-FLEX MOUNTINGS WITH POSITIONING PIN				
MODEL	MAX LOAD (LBS)	DEFLECTION (IN)	SPRING RATE (LB/IN)	SPRING COLOR CODE
CP-1D-85	85	1.35	63	LT PURPLE
CP-1D-120	120	1.20	100	DK YELLOW
CP-1D-175	175	1.17	150	DK BLUE
CP-1D-250	250	1.40	179	YELLOW
CP-1D-340	340	1.13	300	RED
CP-1D-510	510	1.02	500	BLACK
CP-1D-675	675	1.32	513	DK PURPLE
CP-1D-900	900	1.02	881	DK GREEN
CP-1D-1200	1200	0.90	1327	GRAY
CP-1D-1360	1360	0.77	1758	WHITE
CP-1D-1785N ¹	1785	0.88	2029	GRAY/RED

NOTES:
 1. TWO NESTED SPRINGS YIELD THIS LOAD. THE COLOR CODE IS FOR OUTER SPRING/ INNER SPRING.

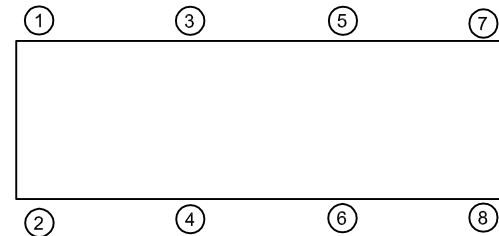

ISOLATOR SELECTIONS	
LOC 1:	LOC 2:
LOC 3:	LOC 4:
LOC 5:	LOC 6:
LOC 7:	LOC 8:
CUSTOMER EQPT. TAG:	

NOTE: MATERIAL SHOWN IS FOR (1) SET.

OTHER MATERIALS, COMPOUNDS, OR FINISHES WITH EQUAL OR SUPERIOR PROPERTIES MAY BE SUBSTITUTED AS THEY BECOME AVAILABLE.

NOTES:

1. ALL DIMENSIONS ARE IN INCHES. INTERPRET PER ANSI Y-14.
2. FINISH: HOUSINGS CAST IRON- ONE COAT BLACK PAINT, SPRINGS- POWDER COAT, HARDWARE- ZINC ELECTROPLATE.
3. REFER TO DRAWING 2 OF 2 FOR INSTALLATION INSTRUCTIONS.
4. INNER SPRING (WHEN USED) NOT SHOWN.
5. ALL SPRINGS ARE DESIGNED WITH 50% OVER-TRAVEL.
6. RATED DEFLECTIONS ARE WITHIN 25% OF NOMINAL. HIGHER DEFLECTIONS ARE ALLOWED IF THEY MEET SPECIFICATIONS.

CERTIFIED FOR:

JOB NAME: _____
 CUSTOMER : _____
 CUSTOMER P.O.: _____
 SALES ORDER: _____

**MODEL CP-1D 85-1785 LBS.
 HOUSED CAST IRON
 SPRING-FLEX ISOLATORS SNUBBED WITH
 POSITIONING PIN
 1 INCH DEFLECTION**



THE VMC GROUP
 The Power of Together
 Bloomingdale, NJ 07403
 Houston, TX 77041

SCALE :
NONE

SHEET:

DRAWING NO.:

REVISION



REV.	DESCRIPTION	DATE	BY

INSTALLATION INSTRUCTION

- ISOLATORS ARE SHIPPED FULLY ASSEMBLED AND ARE TO BE SPACED AND ARRANGED IN ACCORDANCE WITH INSTALLATION DRAWINGS OR AS OTHERWISE RECOMMENDED.
- SET ISOLATORS ON FLOOR OR SUB-BASE, ENSURING THAT ALL ISOLATOR CENTERLINES MATCH THE EQUIPMENT ISOLATING HOLES. SHIM OR GROUT AS REQUIRED LEVELING ALL ISOLATOR BASE PLATES "E" AT THE SAME ELEVATION (1/4" MAXIMUM DIFFERENCE IN ELEVATION CAN BE TOLERATED). ISOLATOR BASE PLATES MUST REST ON A FLAT SURFACE.
- UNLESS SPECIFIED, ISOLATORS NEED NOT BE FASTENED TO FLOOR IN ANY WAY. IF REQUIRED, BOLT ISOLATING TO FLOOR THROUGH SLOTS "D". RECOMMENDED MAXIMUM TORQUING OF ISOLATOR BASE ANCHORS TO 5 FT-# AFTER EQUIPMENT IS INSTALLED.
- PLACE MACHINE OR EQUIPMENT ONTO TOP PLATE "A" OF ISOLATOR, ENSURING THAT THE PIN "P" IS INSERTED INTO THE EQUIPMENT ISOLATING HOLES. THE WEIGHT OF THE MACHINE WILL CAUSE THE UPPER HOUSING OF THE ISOLATOR TO GO DOWN, POSSIBLY RESTING ON THE LOWER HOUSING.
- ADJUST EACH ISOLATOR IN SEQUENCE; SCREW DOWN ONE COMPLETE TURN ON THE ADJUSTING BOLT (B) OF EACH ISOLATORS. ADJUST UNTIL 1/4" GAP IS OBTAINED ON ALL ISOLATORS.
- INSTALLATION IS COMPLETE.

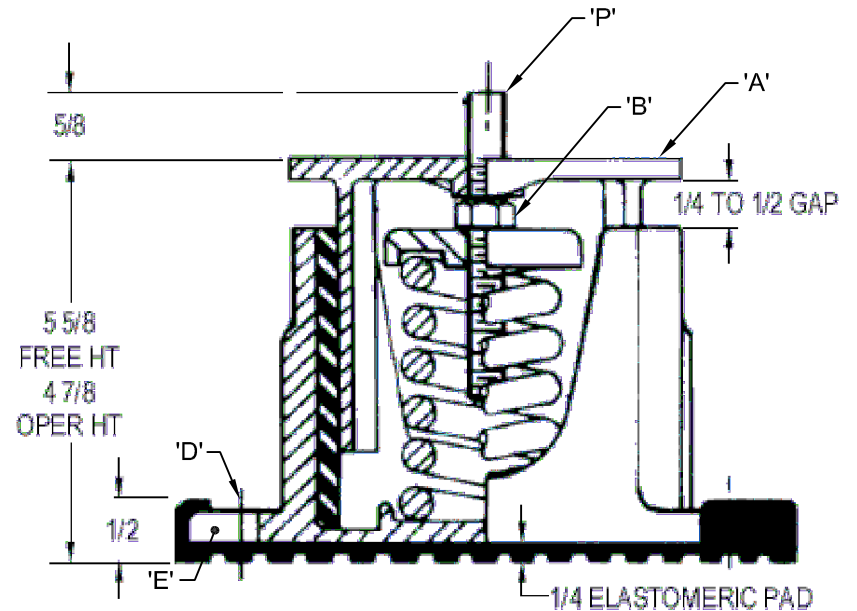

OTHER MATERIALS, COMPOUNDS, OR FINISHES WITH EQUAL OR SUPERIOR PROPERTIES MAY BE SUBSTITUTED AS THEY BECOME AVAILABLE.

CERTIFIED FOR:

JOB NAME: _____
 CUSTOMER: _____
 CUSTOMER P.O.: _____
 SALES ORDER: _____

**MODEL CP-1D 85-1785 LBS.
 HOUSED CAST IRON
 SPRING-FLEX ISOLATORS SNUBBED WITH
 POSITIONING PIN
 1 INCH DEFLECTION**



THE VMC GROUP
The Power of Together
 Bloomingdale, NJ 07403
 Houston, TX 77041

SCALE: NONE
 SHEET: _____



DRAWING NO.: _____ REVISION: _____