

120R-101672 REV.: 5

REV.	DESCRIPTION	DATE	BY

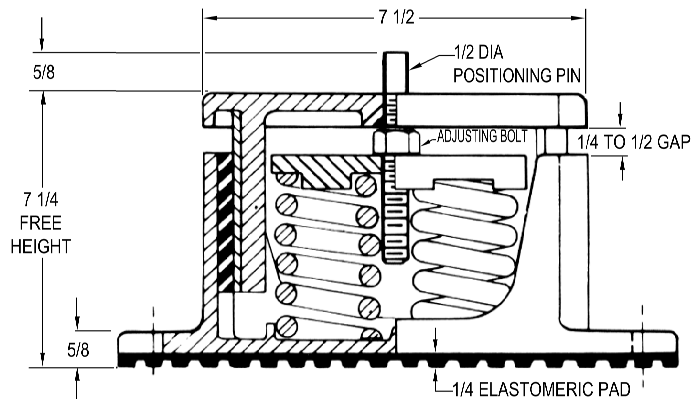
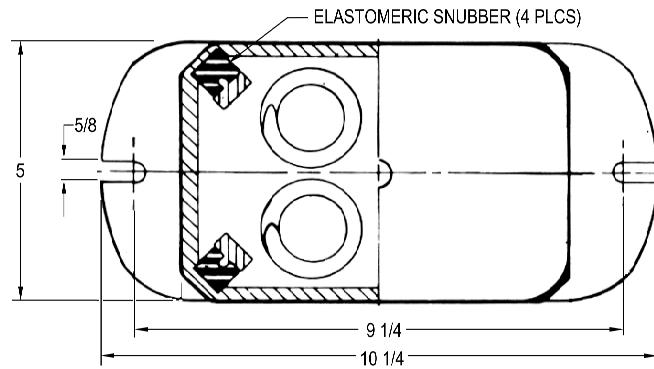

TYPE C4DP-2B CAST IRON SPRING-FLEX ISOLATORS WITH POSITIONING PIN				
MODEL	MAX LOAD (LBS)	DEFLECTION (IN)	SPRING RATE (LB/IN)	SPRING COLOR CODE
C4DP-2B-760	760	2.13	356	BLACK
C4DP-2B-1400	1400	1.86	752	RED
C4DP-2B-2200	2200	1.54	1428	GRAY
C4DP-2B-2660N ¹	2660	1.54	1728	GRAY/ORANGE
C4DP-2B-3060N ¹	3060	1.54	1988	GRAY/DK BROWN

NOTES:
 1. TWO NESTED SPRINGS YIELD THIS LOAD. THE COLOR CODE INDICATED IS FOR OUTER SPRING/ INNER SPRING.

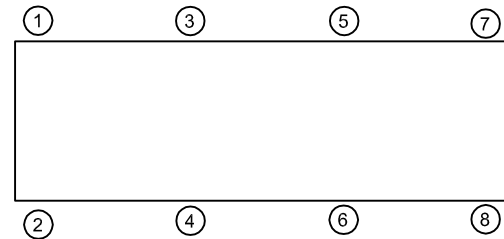

ISOLATOR SELECTIONS	
LOC 1:	LOC 2:
LOC 3:	LOC 4:
LOC 5:	LOC 6:
LOC 7:	LOC 8:
CUSTOMER EQP'T. TAG:	

NOTE: MATERIAL SHOWN IS FOR (1) SET.

NOTES:

1. ALL DIMENSIONS ARE IN INCHES. INTERPRET PER ANSI Y-14.
2. FINISH: HOUSINGS CAST IRON- ONE COAT BLACK PAINT, SPRINGS-POWDER COAT, HARDWARE- ZINC ELECTROPLATE.
3. REFER TO DRAWING 2 OF 2 FOR INSTALLATION INSTRUCTIONS.
4. INNER SPRING (WHEN USED) NOT SHOWN.
5. ALL SPRINGS ARE DESIGNED WITH 50% OVER-TRAVEL.
6. RATED DEFLECTIONS ARE WITHIN 25% OF NOMINAL. HIGHER DEFLECTIONS ARE ALLOWED IF THEY MEET SPECIFICATIONS.

OTHER MATERIALS, COMPOUNDS, OR FINISHES WITH EQUAL OR SUPERIOR PROPERTIES MAY BE SUBSTITUTED AS THEY BECOME AVAILABLE.

CERTIFIED FOR:

JOB NAME: _____

CUSTOMER : _____

CUSTOMER P.O.: _____

SALES ORDER: _____

**MODEL C4DP-2B 760-3060 LBS.
 HOUSED CAST IRON
 SPRING-FLEX ISOLATORS SNUBBED WITH
 POSITIONING PIN
 2 INCH DEFLECTION**



THE VMC GROUP
The Power of Together
 Bloomingdale, NJ 07403
 Houston, TX 77041

SCALE :

NONE

SHEET:



DRAWING NO.:

REVISION

REV.	DESCRIPTION	DATE	BY

INSTALLATION INSTRUCTION

- ISOLATORS ARE SHIPPED FULLY ASSEMBLED AND ARE TO BE SPACED AND ARRANGED IN ACCORDANCE WITH INSTALLATION DRAWINGS OR AS OTHERWISE RECOMMENDED.
- SET ISOLATORS ON FLOOR OR SUB-BASE, ENSURING THAT ALL ISOLATOR CENTERLINES MATCH THE EQUIPMENT ISOLATING HOLES. SHIM OR GROUT AS REQUIRED LEVELING ALL ISOLATOR BASE PLATES "E" AT THE SAME ELEVATION (1/4" MAXIMUM DIFFERENCE IN ELEVATION CAN BE TOLERATED). ISOLATOR BASE PLATES MUST REST ON A FLAT SURFACE.
- UNLESS SPECIFIED, ISOLATORS NEED NOT BE FASTENED TO FLOOR IN ANY WAY. IF REQUIRED, BOLT ISOLATING TO FLOOR THROUGH SLOTS "D". RECOMMENDED MAXIMUM TORQUING OF ISOLATOR BASE ANCHORS TO 5 FT-# AFTER EQUIPMENT IS INSTALLED.
- PLACE MACHINE OR EQUIPMENT ONTO TOP PLATE "A" OF ISOLATOR, ENSURING THAT THE PIN "P" IS INSERTED INTO THE EQUIPMENT ISOLATING HOLES. THE WEIGHT OF THE MACHINE WILL CAUSE THE UPPER HOUSING OF THE ISOLATOR TO GO DOWN, POSSIBLY RESTING ON THE LOWER HOUSING.
- ADJUST EACH ISOLATOR IN SEQUENCE; SCREW DOWN ONE COMPLETE TURN ON THE ADJUSTING BOLT (B) OF EACH ISOLATORS. ADJUST UNTIL 1/4" GAP IS OBTAINED ON ALL ISOLATORS.
- INSTALLATION IS COMPLETE.

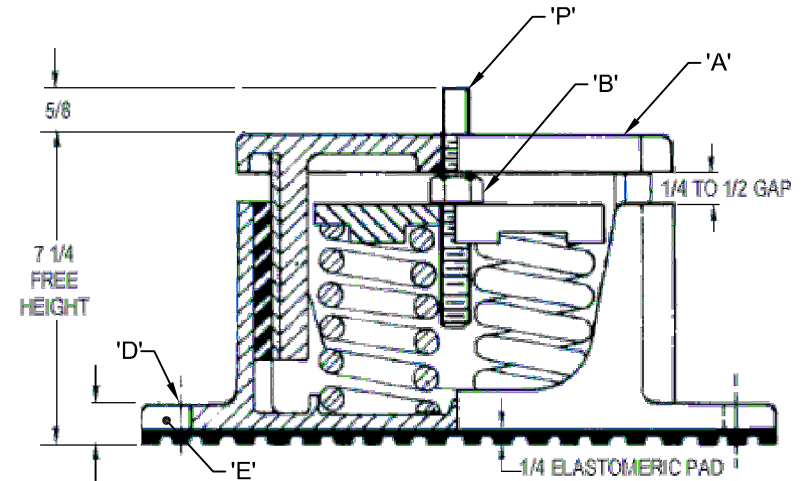

OTHER MATERIALS, COMPOUNDS, OR FINISHES WITH EQUAL OR SUPERIOR PROPERTIES MAY BE SUBSTITUTED AS THEY BECOME AVAILABLE.

CERTIFIED FOR:

JOB NAME: _____
 CUSTOMER: _____
 CUSTOMER P.O.: _____
 SALES ORDER: _____

**MODEL C4DP-2B 760-3060 LBS.
 HOUSED CAST IRON
 SPRING-FLEX ISOLATORS SNUBBED WITH
 POSITIONING PIN
 2 INCH DEFLECTION**



THE VMC GROUP
The Power of Together
 Bloomingdale, NJ 07403
 Houston, TX 77041

SCALE:
 NONE



SHEET:

DRAWING NO.: _____ REVISION