

REV.	DESCRIPTION	DATE	BY

STYLE AW  
MODEL AW-3C

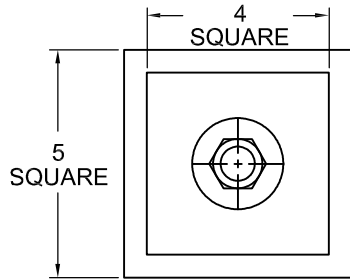

STYLE AWH  
MODEL AWH-3C

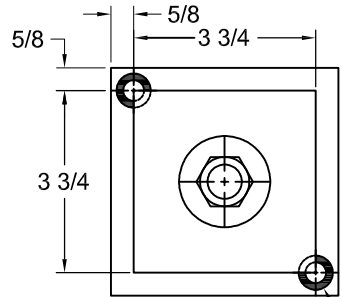

ELASTOMERIC GROMMET  
FOR 1/2 ANCHOR BOLTS

MODEL AW & AWH-3C SPRING-FLEX ISOLATORS				
MODEL	MAX LOAD (LBS)	DEFLECTION (IN)	SPRING RATE (LB/IN)	SPRING COLOR CODE
AW*-3C-75 <sup>2</sup>	75	3.00	25	WHITE
AW*-3C-145 <sup>2</sup>	145	2.90	50	LT PURPLE
AW*-3C-215 <sup>2</sup>	215	2.59	83	LT BROWN
AW*-3C-315 <sup>2</sup>	315	2.37	133	ORANGE
AW*-3C-470 <sup>2</sup>	470	2.35	200	DK BROWN
AW*-3C-600 <sup>2</sup>	600	2.25	267	DK PURPLE
AW*-3C-860N <sup>1,2</sup>	860	2.25	383	ORANGE/RED
AW*-3C-1055N <sup>1,2</sup>	1055	2.34	450	DK BROWN/RED
AW*-3C-1165N <sup>1,2</sup>	1165	2.25	517	DK PURPLE/RED

NOTES:

- TWO NESTED SPRINGS YIELD THIS LOAD. THE COLOR CODE INDICATED IS FOR OUTER SPRING/ INNER SPRING.
- TO COMPLETE MODEL NUMBER, ADD STYLE LETTER (IF USED) IN PLACE OF \*.
- LOAD WILL BE LABELED ON ISOLATOR AND STENCILED ON BASE PLATE.

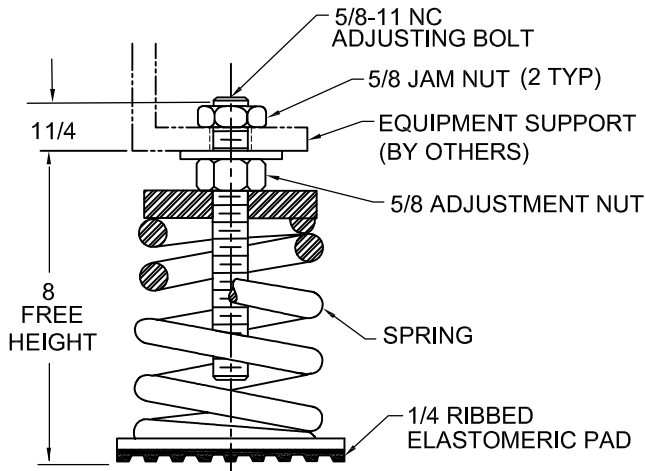

NOTES:

- ALL DIMENSIONS ARE IN INCHES. INTERPRET PER ANSI Y-14.
- FINISH: HOUSING- ONE COAT BLACK PAINT, SPRING- BLACK PAINT, HARDWARE- ZINC ELECTROPLATE.
- REFER TO DRAWING 2 OF 2 FOR INSTALLATION INSTRUCTIONS.
- INNER SPRING (WHEN USED) NOT SHOWN.
- ALL SPRINGS DESIGNED WITH 50% OVER-TRAVEL.
- RATED DEFLECTIONS ARE WITHIN 25% OF NOMINAL. HIGHER DEFLECTIONS ARE ALLOWED IF THEY MEET SPECIFICATIONS.



ISOLATOR SELECTIONS	
LOC 1:	LOC 2:
LOC 3:	LOC 4:
LOC 5:	LOC 6:
LOC 7:	LOC 8:
CUSTOMER EQPT. TAG:	

NOTE: MATERIAL SHOWN IS FOR (1) SET.

OTHER MATERIALS, COMPOUNDS, OR FINISHES WITH EQUAL OR SUPERIOR PROPERTIES MAY BE SUBSTITUTED AS THEY BECOME AVAILABLE.

CERTIFIED FOR:

JOB NAME: \_\_\_\_\_  
 CUSTOMER: \_\_\_\_\_  
 CUSTOMER P.O.: \_\_\_\_\_  
 SALES ORDER: \_\_\_\_\_

MODEL AW AND AWH-3C 75-1165 LBS.  
 OPEN SPRING- FLEX ISOLATORS  
 3 INCH DEFLECTION



**THE VMC GROUP**  
 The Power of Together  
 Bloomingdale, NJ 07403  
 Houston, TX 77041

SCALE:

NONE

SHEET:



DRAWING NO.:

REVISION

REV.	DESCRIPTION	DATE	BY

### INSTALLATION INSTRUCTION

- ISOLATORS ARE SHIPPED FULLY ASSEMBLED AND ARE TO BE SPACED AND ARRANGED IN ACCORDANCE WITH INSTALLATION DRAWINGS OR AS OTHERWISE RECOMMENDED.
- SET ISOLATORS ON FLOOR OR SUB-BASE, ENSURING THAT ALL ISOLATOR CENTERLINES MATCH THE EQUIPMENT MOUNTING HOLES OR SPACE AND ARRANGE ISOLATORS IN ACCORDANCE WITH THE INSTALLATION DRAWING. SHIM OR GROUT AS REQUIRED LEVELING ALL ISOLATOR BASE PLATES AT THE SAME ELEVATION (1/4" MAXIMUM DIFFERENCE IN ELEVATION CAN BE TOLERATED). ISOLATOR BASE MUST REST ON A FLAT SURFACE.
- DESIGNATION OF ISOLATORS IS SHOWN ON TAG / LABEL ATTACHED TO EACH ISOLATOR OR ISOLATORS MAY BE IDENTIFIED BY SIZE OF BASE PLATE AND / OR SPRING COLOR CODE.
- IF FLOOR FASTENING IS REQUIRED, PLACE MOUNT AS INDICATED ON NOTE 1 THRU 3 AND ANCHOR USING (2) ANCHOR THRU HOLES "I" ON STEEL PLATE "G" (APPLIES ONLY TO **STYLE AWH** MOUNT).
- REMOVE JAM NUT "B" FROM ADJUSTING BOLT "A", TURN ADJUSTING NUT "D" COUNTER-CLOCKWISE TO SET "H" FOR ALL ISOLATORS.
- POSITION EQUIPMENT OVER THE ISOLATORS, ALIGN MOUNT ADJUSTING BOLT "A" TO EQUIPMENT BASE MOUNTING THRU HOLES.
- LOWER EQUIPMENT UNTIL IT REST ON ADJUSTING NUT WASHER "C" (SPRING WILL COMPRESS)
- INSERT JAM NUT "B" ON ADJUSTING BOLT "A".
- LEVEL EQUIPMENT BY TURNING ADJUSTING NUT "D" AS REQUIRED
- TIGHTEN JAM NUT "B". INSTALLATION IS COMPLETE

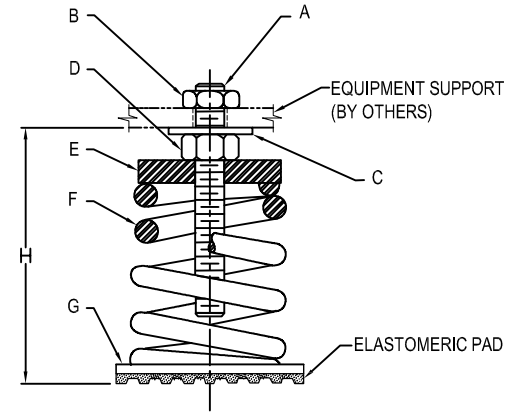

STYLE - AW

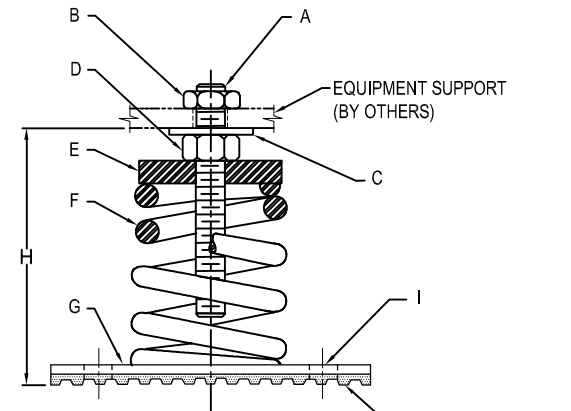

STYLE - AWH

OTHER MATERIALS, COMPOUNDS, OR FINISHES WITH EQUAL OR SUPERIOR PROPERTIES MAY BE SUBSTITUTED AS THEY BECOME AVAILABLE.

**CERTIFIED FOR:**

JOB NAME: \_\_\_\_\_  
 CUSTOMER : \_\_\_\_\_  
 CUSTOMER P.O.: \_\_\_\_\_  
 SALES ORDER: \_\_\_\_\_

**MODEL AW AND AWH-3C 75-1165 LBS.  
 OPEN SPRING- FLEX ISOLATORS  
 3 INCH DEFLECTION**



**THE VMC GROUP**  
*The Power of Together*  
 Bloomingdale, NJ 07403  
 Houston, TX 77041

SCALE:

NONE

SHEET:



DRAWING NO.:

REVISION