

130R-101818 REV: 6

REV.	DESCRIPTION	DATE	BY

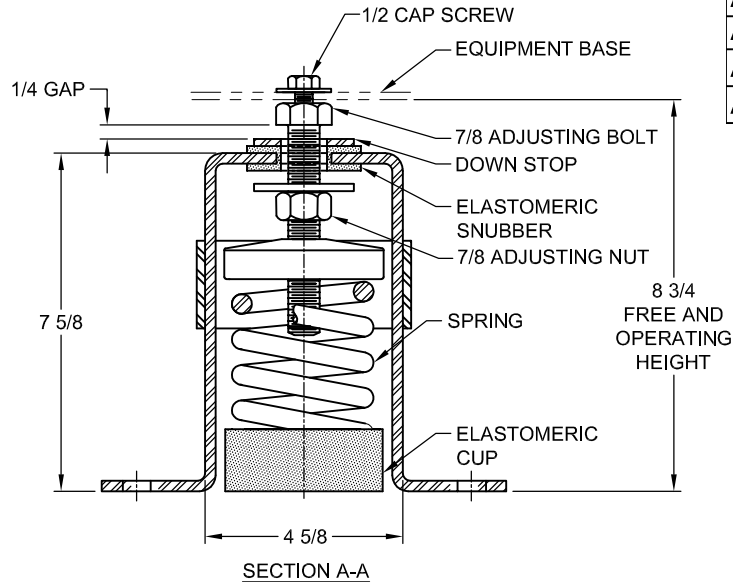
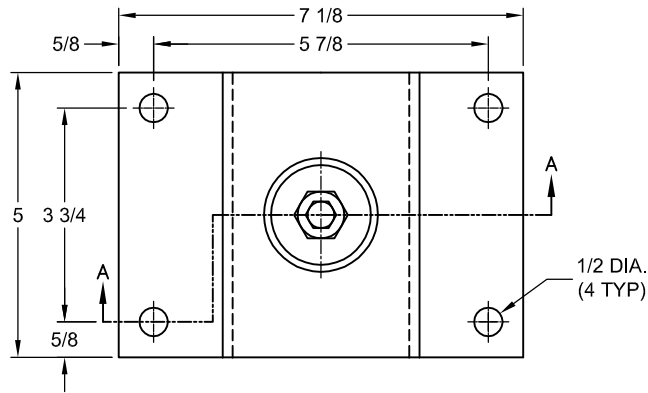

NOTES:

- STANDARD ISOLATOR FINISH: CASTING AND HOUSING- ONE COAT BLACK PAINT, SPRING- POWDER COAT, HARDWARE- ZINC ELECTROPLATE, .
- STATIC LOAD RATINGS ON SHEET 2 OF 2 ARE FOR GUIDANCE ONLY.
- RATED DEFLECTIONS ARE WITHIN 25% OF NOMINAL. HIGHER DEFLECTIONS ARE ALLOWED IF THEY MEET SPECIFICATIONS.

TYPE ASCM-2D SEISMIC ISOLATORS FOR NOMINAL 2" DEFLECTION				
MODEL	MAX LOAD (LBS)	DEFLECTION (IN)	SPRING RATE (LB/IN)	SPRING COLOR CODE
ASCM-2D-75	75	2.42	31	WHITE
ASCM-2D-160	160	2.29	70	YELLOW
ASCM-2D-230	230	2.30	100	GREEN
ASCM-2D-355	355	2.15	165	DK BROWN
ASCM-2D-435	435	1.89	230	RED
ASCM-2D-600N ¹	600	1.88	319	RED/BLACK
ASCM-2D-725	725	1.61	450	TAN
ASCM-2D-845	845	1.48	570	PINK
ASCM-2D-1000N ¹	1000	1.69	592	PINK/BLACK
ASCM-2D-1320N ¹	1320	1.54	857	PINK/GRAY

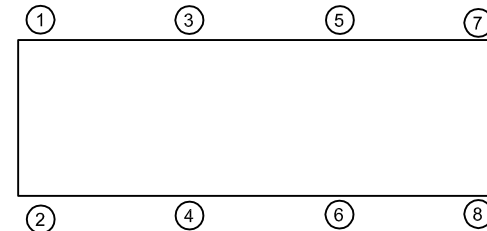

ISOLATOR SELECTIONS	
LOC 1:	LOC 2:
LOC 3:	LOC 4:
LOC 5:	LOC 6:
LOC 7:	LOC 8:
CUSTOMER EQP'T. TAG:	

NOTE: MATERIAL SHOWN IS FOR (1) SET.

OTHER MATERIALS, COMPOUNDS, OR FINISHES WITH EQUAL OR SUPERIOR PROPERTIES MAY BE SUBSTITUTED AS THEY BECOME AVAILABLE.

CERTIFIED FOR:

JOB NAME: _____
 CUSTOMER : _____
 CUSTOMER P.O.: _____
 SALES ORDER: _____

**MODEL ASCM-2D 75-1320 LBS.
 SEISMIC ISOLATORS
 2 INCH DEFLECTION**



THE VMC GROUP
The Power of Together
 Bloomingdale, NJ 07403
 Houston, TX 77041

SCALE :
NONE
 SHEET:



DRAWING NO.: _____ REVISION

REV.	DESCRIPTION	DATE	BY

INSTALLATION INSTRUCTION FOR VMC SERIES ASCM

- ISOLATORS ARE SHIPPED FULLY ASSEMBLED AND ARE TO BE SPACED AND ARRANGED IN ACCORDANCE WITH INSTALLATION DRAWINGS OR AS OTHERWISE RECOMMENDED. MOUNT SHOULD BE ORIENTED WITH THE SPRING FACING OUTWARD FROM EQUIPMENT OR BASE.
- TO FACILITATE INSTALLATION, PRIOR TO INSTALLING, THE VMC GROUP RECOMMENDS TURNING THE ADJUSTING BOLT SO THAT THE "OPERATING GAP" IS APPROXIMATELY 2" TO 2 1/2" FOR 2" DEFLECTION MOUNTS.
- SET ISOLATORS ON SUB BASE. SHIM AND OR GROUT AS REQUIRED, LEVELING ALL ISOLATOR BASES AT THE SAME ELEVATION (1/4" MAXIMUM DIFFERENCE IN ELEVATION CAN BE TOLERATED). ISOLATOR BASE MUST REST ON A FLAT SURFACE.
- ANCHOR ALL ISOLATORS TO FLOOR OR SUB BASE USING ISOLATOR BASE THRU HOLES AS REQUIRED. FOR INSTALLING ON CONCRETE THE VMC GROUP RECOMMENDS HILTI TYPE HSL HEAVY-DUTY ANCHORS OR EQUAL.
- REMOVE CAP SCREW AND SAVE. GENTLY PLACE MACHINE OR MACHINE BASE ON TOP OF ADJUSTING BOLT. INSTALL CAP SCREW, BUT DO NOT TIGHTEN.
- THE WEIGHT OF THE MACHINE WILL CAUSE THE SPRING AND THE ADJUSTMENT BOLT TO DESCEND.
- ADJUST ALL ISOLATORS BY TURNING THE ADJUSTMENT BOLT AND NUT SO THAT THE OPERATING CLEARANCE AND GAP IS APPROXIMATELY 1/4".
- FINE TUNE AND ADJUST TO LEVEL EQUIPMENT.
- TIGHTEN CAP SCREW. INSTALLATION IS COMPLETE.

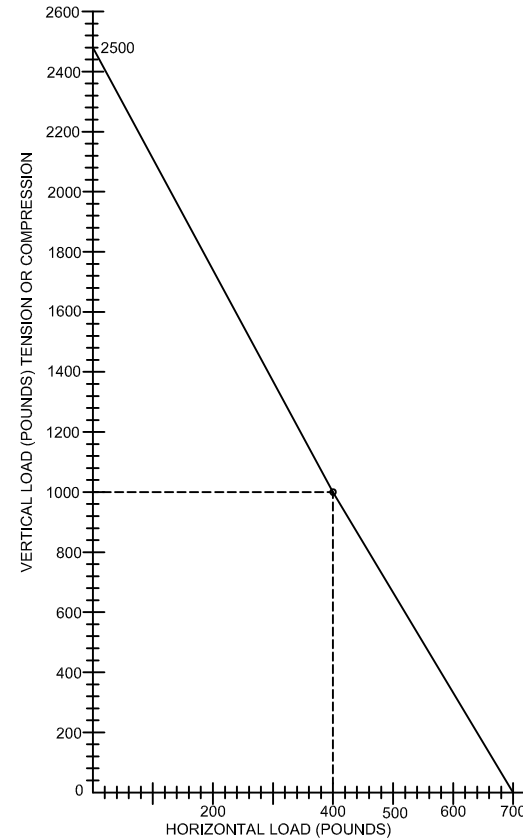

FIGURE 1
RATED LOADS FOR
ASCM-2D-75 THRU -2D-1320N
 (SEE SHEET 1 FOR STATIC RATED LOADS)

OTHER MATERIALS, COMPOUNDS, OR FINISHES WITH EQUAL OR SUPERIOR PROPERTIES MAY BE SUBSTITUTED AS THEY BECOME AVAILABLE.

CERTIFIED FOR:

JOB NAME: _____
 CUSTOMER : _____
 CUSTOMER P.O.: _____
 SALES ORDER: _____

MODEL ASCM-2D 75-1320 LBS.
SEISMIC ISOLATORS
2 INCH DEFLECTION



THE VMC GROUP
The Power of Together
 Bloomingdale, NJ 07403
 Houston, TX 77041

SCALE :
NONE
 SHEET:



DRAWING NO.: _____ REVISION