

180R-102215 REV.: 3

REV.	DESCRIPTION	DATE	BY

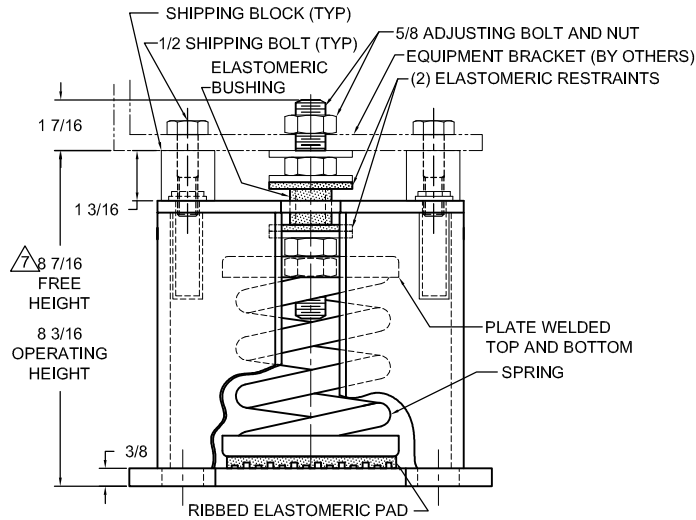
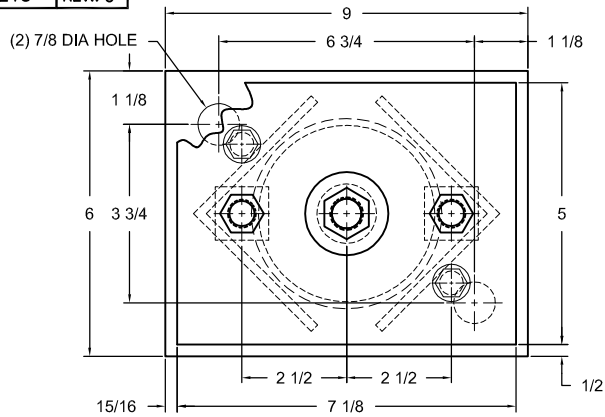

TYPE AMSR-2E-2B SEISMICALLY RESTRAINED SPRING VIBRATION ISOLATORS WITH SHIPPING BLOCK						
MODEL	RATED LOAD (LBS)	RATED DEFLECTION (IN)	SPRING RATE (LB/IN)	SPRING COLOR CODE	ALLOWABLE G RATING <sup>2</sup>	
					HORIZONTAL	VERTICAL
AMSR-2E-80-SB	80	2.00	40	BLACK	17.5	23.1
AMSR-2E-150-SB	150	2.00	75	GREEN	9.3	12.3
AMSR-2E-300-SB	300	2.00	150	DK YELLOW	4.7	6.2
AMSR-2E-500-SB	500	2.00	250	BLUE	2.8	3.7
AMSR-2E-1000-SB	1000	2.00	500	TAN	1.4	1.9
AMSR-2E-1400-SB	1400	1.87	750	RED	1.0	1.3
AMSR-2E-1600N <sup>1</sup> -SB	1600	2.13	750	TAN/RED	0.9	1.2
AMSR-2E-1800-SB	1800	1.71	1050	DK GRAY	0.8	1.0
AMSR-2E-2050-SB	2050	1.64	1250	DK BLUE	0.7	0.9
AMSR-2E-2250N <sup>1</sup> -SB	2250	1.62	1388	DK BLUE/BLACK	0.6	0.8
AMSR-2E-2460N <sup>1</sup> -SB	2460	1.64	1500	DK BLUE/RED	0.6	0.8
AMSR-2E-2700N <sup>1</sup> -SB	2700	1.64	1650	DK BLUE/ DK GREEN	0.5	0.7

TABLE NOTES:  
 1. TWO NESTED SPRINGS YIELD THIS LOAD.  
 2. ALL ALLOWABLE G RATINGS ARE BASED ON HILTI KWIKBOLT TZ WEDGE ANCHORS (OR EQUAL) IN STONE AND AGGREGATE CONCRETE (F<sub>c</sub>=3000 PSI).  
 3. RATED LOAD OF ISOLATOR IS STAMPED ON SPRING ASSEMBLY BASE PLATE.

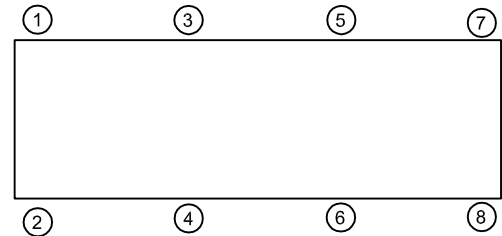

- NOTES
- ALL DIMENSIONS ARE IN INCHES. INTERPRET PER ANSI Y-14.
  - FINISH: HOUSING- ONE COAT BLACK PAINT, SPRING- BLACK PAINT, HARDWARE- ZINC ELECTROPLATE.
  - INNER NESTED SPRING, WHEN USED, NOT SHOWN. SEE SPRING TABLE, NOTE 1.
  - ALL SPRINGS DESIGNED WITH 50% OVER-TRAVEL.
  - REFER TO TABLE ABOVE FOR ALLOWABLE HORIZONTAL AND VERTICAL G RATINGS. SEE TABLE NOTE 2.
  - ISOLATOR HAS BEEN FACTORY PRE-COMPRESSED A NOMINAL 1/2 INCHES.
  - PRIOR TO MOUNTING EQUIPMENT, THE INTERNAL VERTICAL RESTRAINT WILL BE AGAINST THE HOUSING TOP PLATE AND THE ADJUSTING NUT WILL BE 1/4" ABOVE THE BLOCK AT THE "FREE HEIGHT." WHEN THE EQUIPMENT IS MOUNTED, THE SPRING WILL DEPRESS AND REST ON THE SHIM AT THE "OPERATING HEIGHT."
  - RATED DEFLECTIONS ARE WITHIN 25% OF NOMINAL. HIGHER DEFLECTIONS ARE ALLOWED IF THEY MEET SPECIFICATIONS.

ISOLATOR SELECTIONS	
LOC 1:	LOC 2:
LOC 3:	LOC 4:
LOC 5:	LOC 6:
LOC 7:	LOC 8:
CUSTOMER EQ'PT. TAG:	

NOTE: MATERIAL SHOWN IS FOR (1) SET.

OTHER MATERIALS, COMPOUNDS, OR FINISHES WITH EQUAL OR SUPERIOR PROPERTIES MAY BE SUBSTITUTED AS THEY BECOME AVAILABLE.

**CERTIFIED FOR:**

JOB NAME: \_\_\_\_\_  
 CUSTOMER: \_\_\_\_\_  
 CUSTOMER P.O.: \_\_\_\_\_  
 SALES ORDER: \_\_\_\_\_

**MODEL AMSR-2E-SB 80-2700 LBS.  
 SEISMIC ISOLATORS  
 WITH SHIPPING BLOCK  
 2 INCH DEFLECTION**



**THE VMC GROUP**  
 The Power of Together  
 Bloomingdale, NJ 07403  
 Houston, TX 77041

SCALE:

NONE

SHEET:



DRAWING NO.:

REVISION

REV.	DESCRIPTION	DATE	BY

**READ INSTRUCTIONS IN THEIR ENTIRETY BEFORE BEGINNING.**

**FACTORY INSTRUCTIONS**

- ISOLATORS ARE SHIPPED FULLY ASSEMBLED AND ARE TO BE SPACED AND ARRANGED IN ACCORDANCE WITH INSTALLATION DRAWINGS OR AS OTHERWISE RECOMMENDED.
- SET ISOLATORS ON FLOOR OR SUB-BASE, ENSURING THAT ALL ISOLATOR CENTERLINES MATCH THE EQUIPMENT MOUNTING HOLES OR SPACE AND ARRANGE ISOLATORS IN ACCORDANCE WITH THE INSTALLATION DRAWING. SHIM OR GROUT AS REQUIRED LEVELING ALL ISOLATOR BASE PLATES AT THE SAME ELEVATION (1/4" MAXIMUM DIFFERENCE IN ELEVATION CAN BE TOLERATED). ISOLATOR BASE MUST REST ON A FLAT SURFACE.
- PRIOR TO MOUNTING EQUIPMENT, INTERNAL STOP "A" WILL BE AGAINST THE TOP PLATE AND WASHER "F" WILL BE APPROXIMATELY 1/4" ABOVE THE SHIPPING BLOCK AT THE "FREE HEIGHT."
- REMOVE SHIPPING BOLT, BUT LEAVE THE SHIPPING BLOCK IN PLACE.
- REMOVE EQUIPMENT ATTACHMENT NUT "B" ON ISOLATOR STUD "C" AND PLACE EQUIPMENT ON ISOLATOR WASHER "F". THE EQUIPMENT WEIGHT WILL COMPRESS THE SPRING INSIDE THE HOUSING AND EQUIPMENT BRACKET WILL REST ON THE SHIPPING BLOCK AT THE "OPERATING HEIGHT."
- TURN THE ADJUSTING NUT "D" UNDER THE WASHER COUNTER-CLOCKWISE TO COMPRESS THE SPRING. WHEN THE LOAD IS EQUALIZED, TURNING THE NUT WILL RAISE THE EQUIPMENT UNTIL THE INTERNAL GAP "G-1" IS APPROXIMATELY EQUAL TO THE EXTERNAL GAP "G-2". (I.E. THE EQUIPMENT CAN MOVE UP OR DOWN, THE SAME DISTANCE IN A SEISMIC EVENT).
- THE ADJUSTING PROCESS SHOULD BE DONE GRADUALLY ON ALL ISOLATORS UNTIL THE EQUIPMENT WEIGHT IS NO LONGER RESTING ON THE SHIPPING BLOCKS.
- REPLACE ISOLATOR ATTACHMENT NUTS "B" ON ADJUSTING BOLTS "C" TO SECURE MACHINE LEGS TO ISOLATORS. HAND TIGHTEN WHERE THERE IS FIRM CONTACT BETWEEN THE NUT AND EQUIPMENT. (HAND TOOLS MAY BE USED.) THEN TIGHTEN THE NUT AN ADDITIONAL 1/3 TURN. REPLACE SHIPPING BOLT AND HAND-TIGHTEN WHERE THERE IS FIRM CONTACT BETWEEN THE BOLT AND EQUIPMENT BRACKET. TOOLS MAY BE USED TO BRING THE BOLT AND METAL COMPONENTS INTO CONTACT. FOLLOWING CONTACT, TIGHTEN THE BOLT ANOTHER 1/3 TURN.

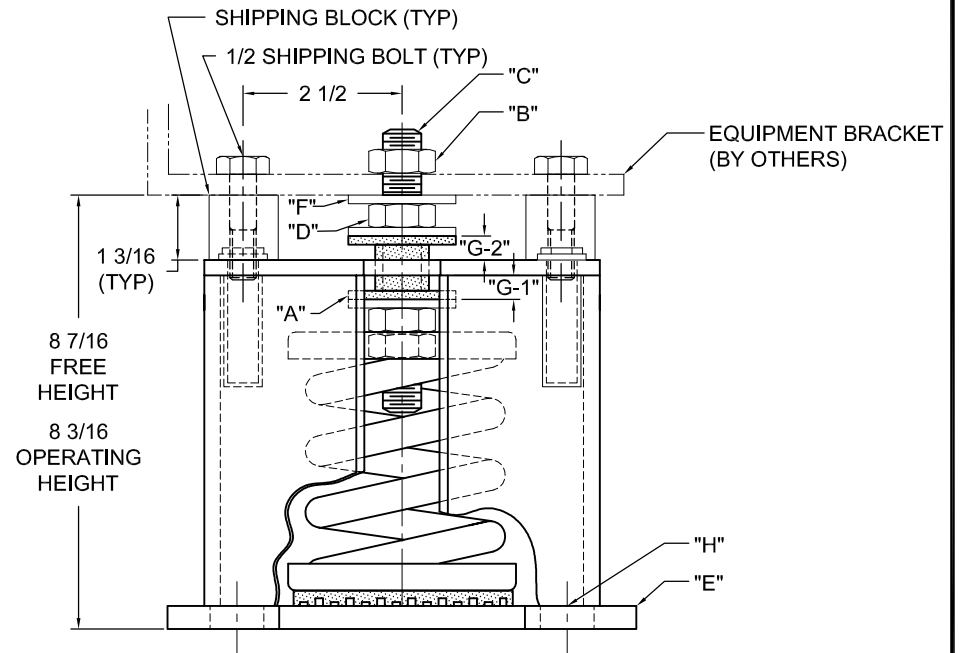

**FIELD INSTRUCTIONS**

- SHIPPING BLOCK FIXES THE EQUIPMENT AT THE OPERATING HEIGHT. AFTER EQUIPMENT IS INSTALLED AT ITS FINAL LOCATION, REMOVE SHIPPING BOLT. IF THE BLOCK WILL NOT SLIDE OUT, TURN ADJUSTING NUT COUNTER-CLOCKWISE UNTIL EQUIPMENT DEAD LOAD IS NO LONGER RESTING ON SHIPPING BLOCK. REMOVE SHIPPING BLOCK AND DISCARD.
- THRUST RESTRAINTS MUST BE ADDED TO THE FAN IF THE TOTAL FAN STATIC PRESSURE IS 2" W.G. OR GREATER.

OTHER MATERIALS, COMPOUNDS, OR FINISHES WITH EQUAL OR SUPERIOR PROPERTIES MAY BE SUBSTITUTED AS THEY BECOME AVAILABLE.

**CERTIFIED FOR:**

JOB NAME: \_\_\_\_\_  
 CUSTOMER: \_\_\_\_\_  
 CUSTOMER P.O.: \_\_\_\_\_  
 SALES ORDER: \_\_\_\_\_

**MODEL AMSR-2E-SB 80-2700 LBS.  
 SEISMIC ISOLATORS  
 WITH SHIPPING BLOCK  
 2 INCH DEFLECTION**



**THE VMC GROUP**  
*The Power of Together*  
 Bloomingdale, NJ 07403  
 Houston, TX 77041

SCALE:

NONE

SHEET:



DRAWING NO.:

REVISION