

REV.	DESCRIPTION	DATE	BY

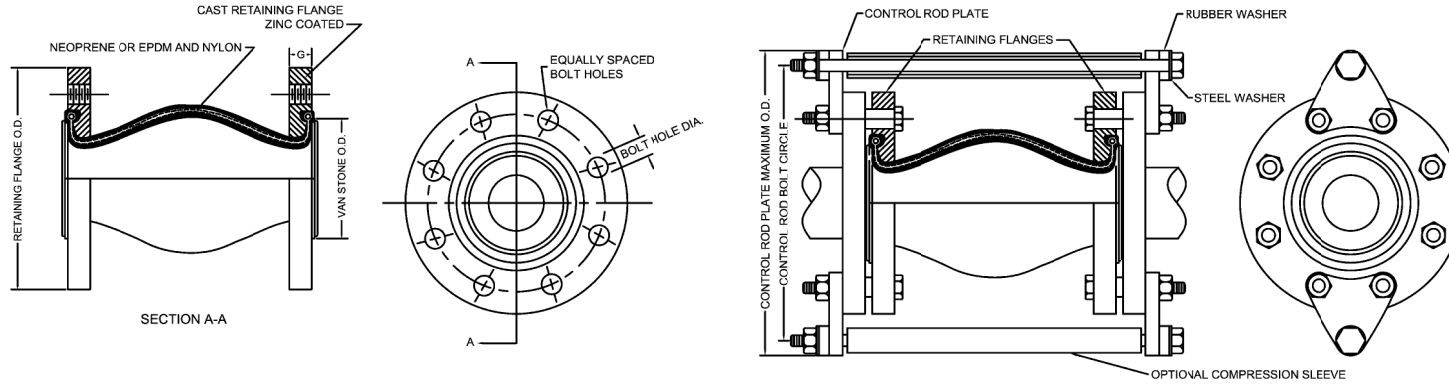

NOMINAL PIPE SIZE	F - INSTALLED LENGTH			ALLOWABLE MOVEMENTS FROM NEUTRAL LENGTH				PRESSURE		FLANGE/BOLTING DIMENSIONS				
	NEUTRAL LENGTH	MAXIMUM COMPRESSED	MAXIMUM EXTENDED	AXIAL COMPRESSION	AXIAL EXTENSION	±LATERAL DEFLECTION	ANGULAR DEFLECTION	POSITIVE PSIG	NEGATIVE IN. OF HG	FLANGE THICKNESS	FLANGE O.D.	BOLT CIRCLE	HOLE QTY.	HOLE SIZE
1-1/4	6	5.500	6.375	0.500	0.380	0.500	31°	225	26	0.47	4.63	3.50	4	0.625
1-1/2	6	5.500	6.375	0.500	0.380	0.500	27°	225	26	0.55	5.00	3.88	4	0.625
2	6	5.500	6.375	0.500	0.375	0.500	20°	225	26	0.63	6.00	4.75	4	0.750
2-1/2	6	5.500	6.375	0.500	0.375	0.500	17°	225	26	0.71	7.00	5.50	4	0.750
3	6	5.500	6.375	0.750	0.375	0.500	14°	225	26	0.71	7.50	6.00	4	0.750
4	6	5.250	6.500	0.750	0.500	0.500	14°	225	26	0.71	9.00	7.50	8	0.750
5	6	5.250	6.500	0.750	0.500	0.500	11°	225	26	0.79	10.00	8.50	8	0.880
6	6	5.250	6.500	0.750	0.500	0.500	9°	225	26	0.87	11.00	9.50	8	0.880
8	6	5.250	6.500	1.000	0.500	0.500	7°	225	26	0.87	13.50	11.75	8	0.880
10	8	7.000	8.625	1.000	0.625	0.750	7°	225	26	0.95	16.00	14.25	12	1.000
12	8	7.000	8.625	1.000	0.625	0.750	6°	225	26	0.95	19.00	17.00	12	1.000
14	8	7.000	8.625	1.000	0.625	0.750	5°	150	26	1.02	21.00	18.78	12	1.130
16	8	7.000	8.625	1.000	0.625	0.750	4°	125	26	1.10	23.50	21.25	16	1.130
18	8	7.000	8.625	1.000	0.625	0.750	4°	125	26	1.18	25.00	22.75	16	1.250
20	8	7.000	9.625	1.000	0.625	0.750	3°	125	26	1.18	27.50	25.00	20	1.250
24	10	9.000	10.625	1.000	0.625	0.750	3°	110	26	1.18	32.06	29.50	20	1.380

- NOTES:
- 1) ALL DIMENSIONS IN INCHES.
  - 2) PRESSURE RATING BASED ON 170 °F OPERATING TEMPERATURE WITH BURST PRESSURE APPROXIMATELY 4 TIMES OPERATING PRESSURE.
  - 3) MAXIMUM OPERATING TEMPERATURE 250 °F.
  - 4) FLOATING STEEL FLANGES DRILLED TO MATE WITH 150# ASA COMPANION FLANGES.
  - 5) FLANGES WILL BE FURNISHED WITH DRILLED HOLES AS STANDARD. TAPPED HOLES AVAILABLE SPECIAL ORDER.
  - 6) CONTROL UNITS ARE REQUIRED WHERE ALLOWABLE MOVEMENTS WILL BE EXCEEDED. UNANCHORED PIPING MUST BE RESTRAINED IN A MANNER TO PREVENT MOVEMENT IN EXCESS OF ALLOWABLE LEVELS.
  - 7) FLANGES WILL BE FURNISHED WITH DRILLED HOLES AS STANDARD. TAPPED HOLES AVAILABLE SPECIAL ORDER.
  - 8) STANDARD EPDM OR NEOPRENE. OTHER MATERIALS ARE AVAILABLE.
  - 9) COMPOUNDS OR FINISHES WITH EQUAL OR SUPERIOR PROPERTIES MAY BE SUBSTITUTED AS THEY BECOME AVAILABLE.
  - 10) REFER TO DRAWINGS II-5210 AND II-5212 FOR INSTALLATION INSTRUCTIONS.

WARNING: EXPANSION JOINTS MAY OPERATE IN PIPELINES OR EQUIPMENT CARRYING FLUIDS AND/OR GASES AT ELEVATED TEMPERATURES AND PRESSURES. NORMAL PRECAUTIONS SHOULD BE TAKEN TO MAKE SURE THESE PARTS ARE INSTALLED CORRECTLY AND INSPECTED REGULARLY. PRECAUTIONS SHOULD BE TAKEN TO PROTECT PERSONNEL IN THE EVENT OF LEAKAGE OR SPLASH.

OTHER MATERIALS, COMPOUNDS OR FINISHES WITH EQUAL OR SUPERIOR PROPERTIES MAY BE SUBSTITUTED AS THEY BECOME AVAILABLE.

**CERTIFIED FOR:**

JOB NAME: \_\_\_\_\_  
 CUSTOMER : \_\_\_\_\_  
 CUSTOMER P.O.: \_\_\_\_\_  
 SALES ORDER: \_\_\_\_\_

**MODEL 2800 RUBBER EXPENSION JOINT  
 SINGLE SPHERE**



**THE VMC GROUP**  
*The Power of Together*  
 Bloomingdale, NJ 07403  
 Houston, TX 77041

SCALE :  
 NONE

SHEET:

DRAWING NO.:

REVISION

