

Lifting column DB

Features:

Very stiff
Short retracted length
Safety factor >4
Limit switches

Options:

Safety nut
Encoder
Customised

Description:

Lifting column DB are designed for medical, ergonomical and industrial application. DB-column are built on X2s stiff aluminium tubes and long life pads, combined with a very tight tolerance assembly – where others squeeze – we fit. The columns perform a stable, reliable and maintenance free guiding system without any play.

DB is available in push or pull version. As an option you can get DB with encoder for positioning or parallel run of 2 or more columns. If you don't find a column in above standard range we can customise for you.

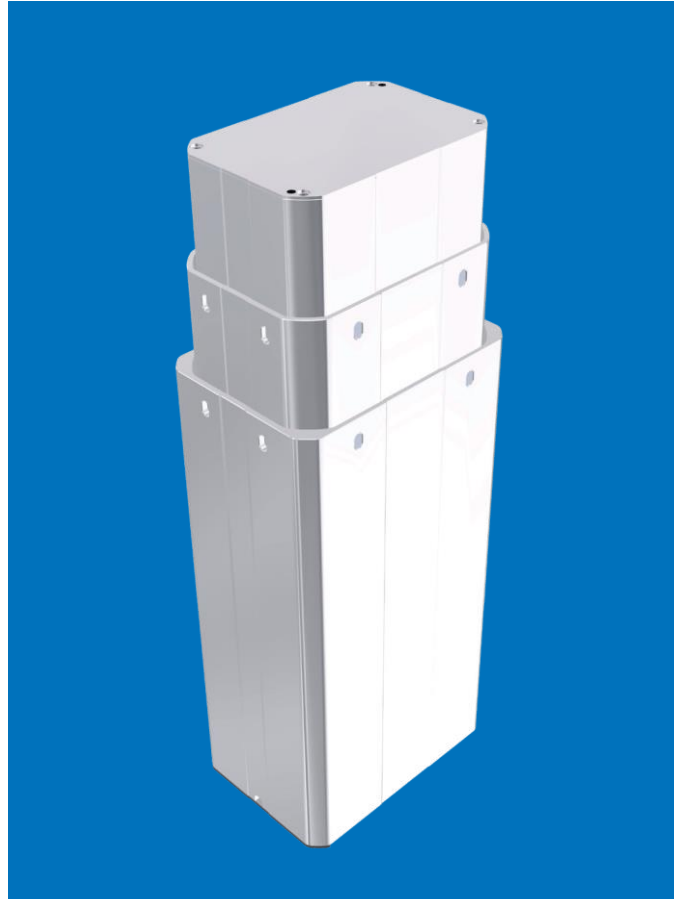

Technical data	DB-AF	DB-AE
Number of sections	3	3
Force* (push or pull) max	2000 N	3000 N
Speed, 0-max load; mm/s	25-13	20-10
Stroke	From 300 mm up to 1000 mm	
Retracted length	Stroke * 0,5 + min 150 mm	
Voltage	24VDC	
Current, 0 to max load	1-6A depending on load	
Duty cycle, on / off	1min on / 9 min off	
Ambient temperature	+10 / +40 °C	
Degree of protection	IP30	

* See offset load diagram on next page

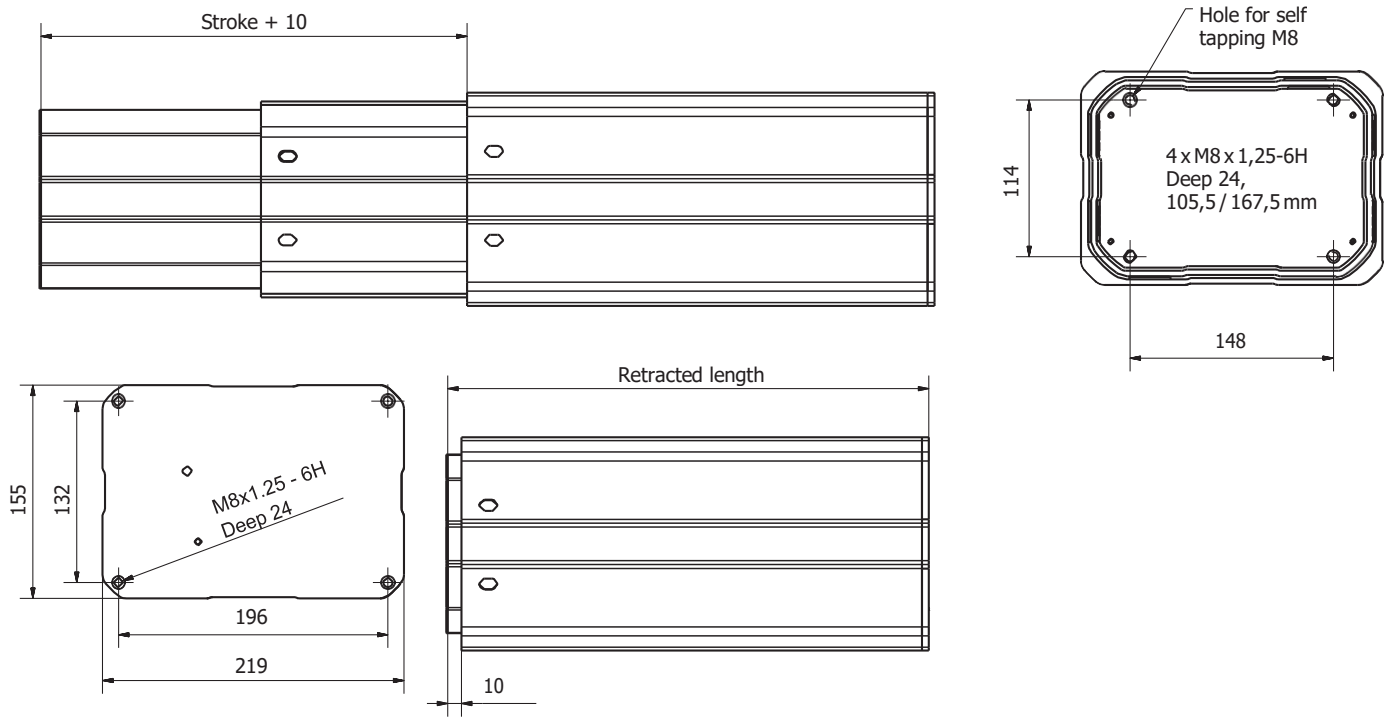

Offset load diagram

