



GAS SPRINGS
FITTINGS & BRACKETS

CONTENTS

INTRODUCTION TO BERTHOLD MARX	P3
SAFETY PROTOCOLE	P4
DÉFINITION AND RECOMMENDATIONS FOR USAGE OF BM GAS SPRINGS	P5
FORCE DIAGRAM	P6
FORCE GAS SPRING CHOICE GUIDE	P7
COMPRESSION SPRINGS WITH WELDED EYES ROD 6, 8 AND 10	P8-9
COMPRESSION SPRINGS WITH M6 THREADED ENDS DIAMETER ROD 6 AND 8	P10
M6 FITTINGS	P11-13
COMPRESSION SPRINGS WITH M8 THREADED ENDS DIAMETER ROD 10 AND 14	P14
M8 FITTINGS	P15-17
COMPRESSION SPRINGS WITH M10 THREADED ENDS DIAMETER ROD 14	P18
M10 FITTINGS	P19
COMPRESSION SPRINGS WITH M14 THREADED ENDS DIAMETER ROD 20	P20
M14 FITTINGS	P21
BRACKETS	P22-23
PROTECTION TUBES / WIPER RING	P24
LOCKING TUBES	P25
STAINLESS STEEL COMPRESSION SPRINGS WITH M8 THREADED END	P26-27
M8 STAINLESS STEEL FITTINGS	P28-29
TRACTION GAS SPRINGS	P30
SPECIAL MADE STEEL COMPRESSION GAS SPRINGS	P31
SPECIAL MADE LOCKING GAS SPRINGS	P32
REQUEST FOR EQUIVALENCE (SCREWED OR WELDED EYES)	P33
REQUEST OF EQUIVALENCE	P34
GENERAL SALES CONDITIONS	P35



All our 3D references are available on
www.traceparts.com

BERTHOLD MARX serving Industry

Created in 1945, the company BERTHOLD MARX supplied industrial body shells to the automotive market, spare parts, as well as various consumables.

After more than 30 years developing in this sector, it was in the 70s, that it became keenly interested in a new component that had just appeared on the market: «**The gas spring**».

The gas spring was created to respond to the issue of weight resulting from the hatchback produced by French car manufacturers. The hatchback now had to incorporate a window which up to then it had not. The gas spring is an essential component of this assembly which enables light and easy handling of the hatchback.

The gas spring therefore became «(the)» part around which the entire company strategy was developed, to the point of a new Gas Spring production plant being established in 2003.

This has enabled the company's range to be extended to all sectors with the need to compensate, fully or partly for a weight, independently, and releasing products adapted to the needs of customers.

With the aim of having a consistent and targeted range of products on the market, BERTHOLD MARX has solely kept in its catalogue all products directly linked to applications with gas springs (rubber sections and seals, silent blocs, etc.)

Our contact details :

BERTHOLD MARX
1 rue de la gravière
67116 REICHSTETT - FRANCE

Phone : +33 3 88 40 31 61
Mail : info@bertholdmarx.com
Site : www.bertholdmarx.com

ISO 9001 Certif

Version 2015



Gas Spring safety protocol

Gas springs are devices containing nitrogen and oil under pressure. This pressure may reach more than 160 bar.

Observe the following precautions:

- Do not subject the gas springs to impacts, vibrations or electrical or magnetic fields.
- Do not expose the gas springs to a temperature exceeding 80°C.
- The rod must remain free of any impurities, splashes, paint, adhesive, solvent or corrosive product.
- Do not force a gas spring with a blocked rod (see Neutralisation section below)
- Do not damage the body of the gas spring (notches, abrasions, cuts) as this may weaken the resistance of the body or an internal component.
- Do not remove the gas spring from the application as the rod is engaged in the body, without having neutralised its beforehand (unless it is completely open, with the rod out).
- Check that the gas spring is not subjected to lateral forces
- Leave a clearance of 0.5 to 1 mm between the gas spring ends and the application's mounting axis in order to enable the welded eyes to rotate on their axes during operation
- Gas Springs must be installed with piston rod pointing down (min. angle of 15°/horizontal)



Neutralising a gas spring:

To neutralise a gas spring, the pressure in its body needs to be released. This operation is necessary before disposing of them or before removing them when they are in the retracted rod position, you need to carry out the following (wear safety goggles and safety gloves):

- Lock the application if the gas spring is still in position.
- Gently lock the gas spring in a vice if it can be removed from the application.
- Use a metal hand saw to carefully saw the gas spring body in an area of between 20 mm and 30 mm from the bottom of the tube (side opposite the spring rod).
- Cover the saw blade in a cloth in order to prevent projections of iron parts or oil.
- When you hear the gas escaping (whistling sound) stop sawing and wait for all the gas to escape from the body.
- Degassing is complete when the rod can be moved without restriction. If this is not the case, make a second notch at the front of the tube (40 mm from the front).
- When disposing of the gas spring place it in a suitable container (the components are mainly metal). The nitrogen used in the gas springs is inert and not hazardous to the environment.
- The oil must be recovered in a suitable recipient and taken to a recycling centre that accepts drained-off oil.

Definition and recommendations for usage for BM® gas springs

Important information. Please read carefully

The gas spring is not a safety component.

1 - DIMENSIONAL AND PRESSURE UNITS

All dimensions are stated in **millimetres (mm)**, all pressures/forces in **Newtons (N/F1)**, and all temperatures in **degrees Celsius (C°)**.

2 - ASSEMBLY PRECAUTIONS

Protect the rods against strikes, electrical arc flashing, grinding sparks, paint and corrosive products. Do not tighten the rods with pliers or in a vice without using protective lead, aluminium or copper jaws.

3 - CONDITIONS OF USE

Number of forward/return movements a minute: 5 maximum. For higher speeds, contact us.

- Durability level: 30,000 cycles. Loss of characteristics after endurance: 15% maximum (the level of durability varies according to the stroke and the calibration).
- Operating temperature: from -30° C to + 80° C (peak).
- Reference temperature: + 20° C force variation due to the temperature: 1% for 3°C.

4 - STORAGE CONDITIONS BEFORE USAGE

- For a maximum period of three months, the devices can be stored horizontally, in a room at ambient temperature..
- For storage over a longer period of time, or in a hot country, store vertically, with the rod downwards.

5 - WARRANTY

- 1 year from the date marked on the equipment. Example of marking: 1011 (10th week of 2011).
- To maintain the warranty, in the case where a device is repainted, the manufacturing date must remain visible..

6 - TOLERANCE MARGINS

Force in Newtons	Tolerance Margin
$30 \leq N < 50$	+ ou - 10N
$50 \leq N < 250$	+ ou - 20 N
$250 \leq N < 750$	+ ou - 30 N
$750 \leq N < 1500$	+ ou - 60 N
$1500 \leq N < 3000$	+ ou - 150 N
$3000 \leq N < 6000$	+ ou - 300 N

Force diagram

- The forces «F1» and «F3» are measured at the distance «C» from the ends.
- The difference between the extension force and the compression force of the spring at the same rod position is due to internal friction «FR».
- The **Progression X** = $F2/F1$.

D1 (mm)	D2 (mm)	Force (F1 en N)	Max stroke (mm)	X (~)	C (mm)	Max FR (N)
6	15	400	150	1.30	5	50
8	18	750	250	1.35	5	60
10	21	1150	400	1.40	5	80
14	27	2100	500	1.50	5	150
20	40	5200	500	1.45	5	300

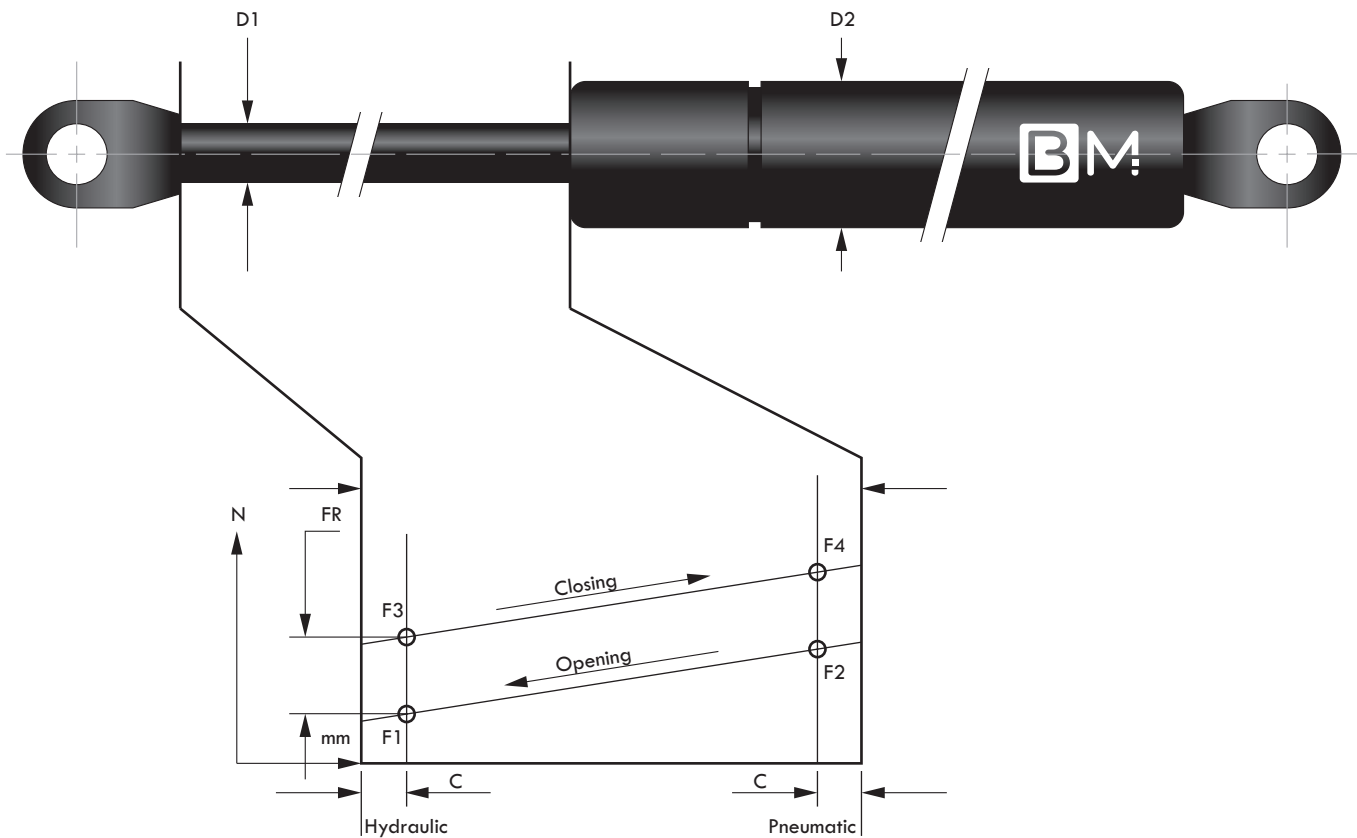

Compression gas spring - Diagram

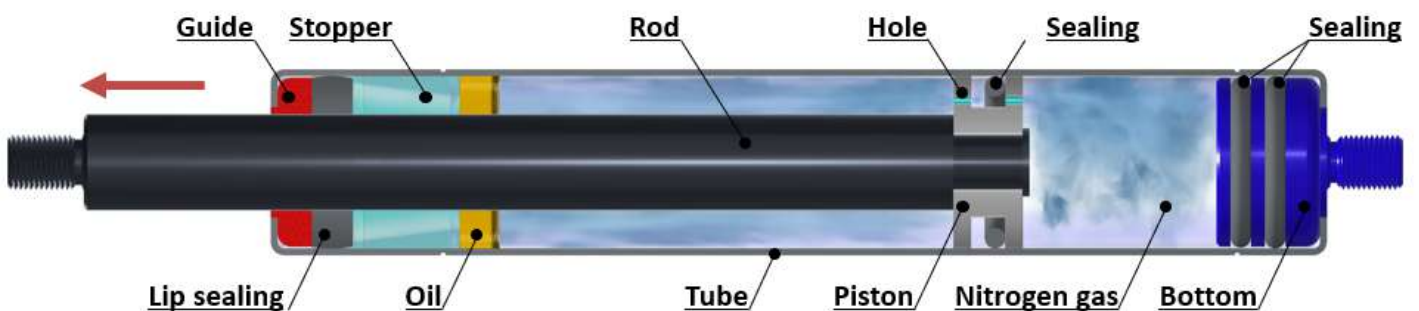

Force gas spring choice guide

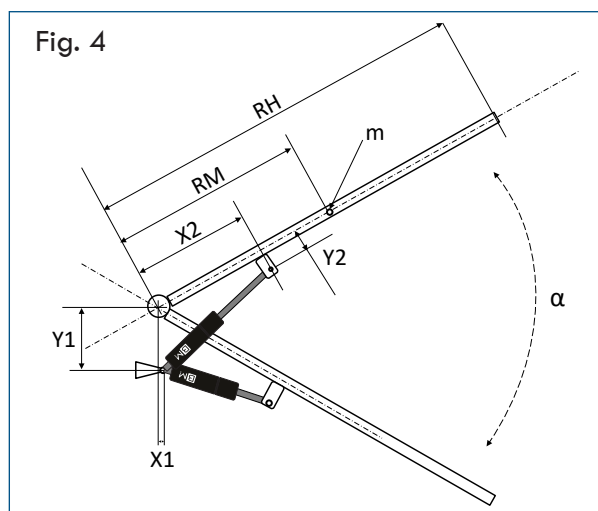
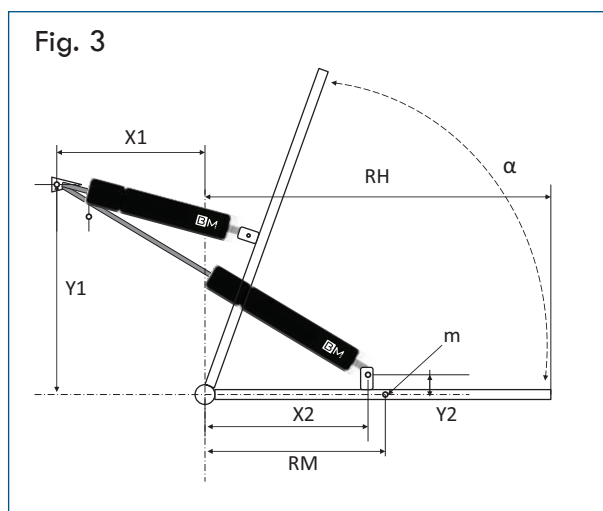
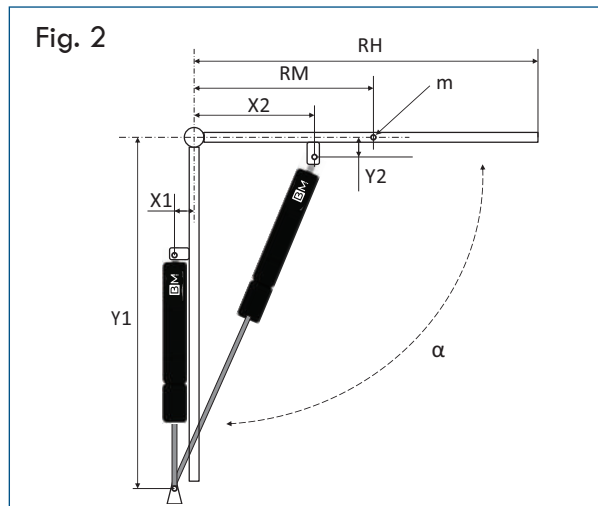
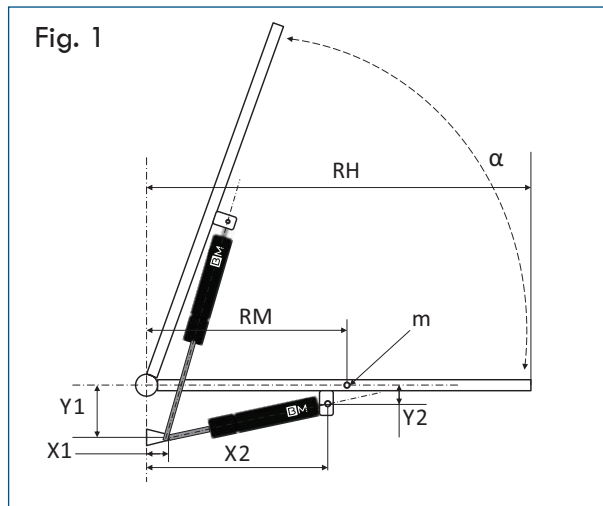

Gas spring - Calculation of FORCE (in Newtons) :

$$F1 \text{ (N)} = 9,81 \times \frac{RH \times m}{2 \times N \times (X2)} + 5$$

N = Number of gas springs

RH = Length of the opening in meters (M)

m = Mass or Weight of the hatch in kilos (KG)

X2 = Lever arm on meters (M)

Warning, we recommend round up to the upper tolerance the result (see page 5 tolerance range)

Other recommendation: The gas spring stroke has a relation with the opening angle of the hatch, and we apply ourself the following recommendation: **STROKE = 1/3 of RH for an angle of 90°**

The above recommendations are given as an indication and do not engage the responsibility of the BM company in any way, given the empirical nature of the method. This calculation method nevertheless gives good results in the majority of cases.

Meaning of the letter codes in the gas springs references

ST

Standard

250Stroke
(mm)**0700**Force
(N)**V**With Thread or
without if no
letter indicated**D8**Ø Rod
(mm)**--**E = Extended Length (mm)
VA = Valve
M = Ø Thread (mm)
T = Ø Hole (mm)
iN = Stainless Steel**Calculate****Order****Delivery in 24 to 48 hours!**

OUR COMPRESSION GAS SPRINGS AND HIS ACCESSORIES

COMPRESSION GAS SPRINGS WITH WELDED EYES ROD 6

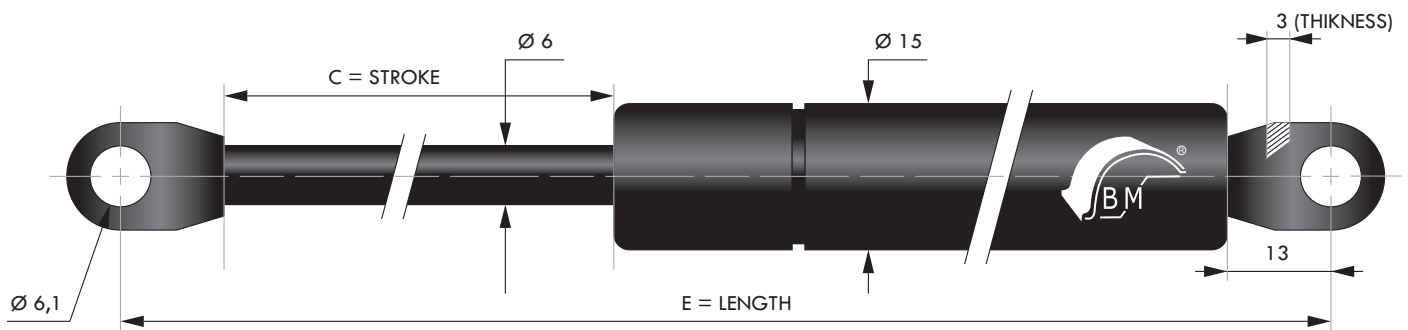

C - Stroke in mm	E - Length in mm	F1 - Force in Newtons	Reference
20	94	De 30 à 250	ST 020+F1+D6
20	106	De 30 à 350	ST 020+F1+D6 E106
40	145	De 30 à 400	ST 040+F1+D6
60	185	De 30 à 400	ST 060+F1+D6
80	225	De 30 à 400	ST 080+F1+D6
100	265	De 30 à 400	ST 100+F1+D6
120	305	De 30 à 400	ST 120+F1+D6
150	365	De 30 à 400	ST 150+F1+D6

COMPRESSION GAS SPRINGS WITH WELDED EYES ROD 8

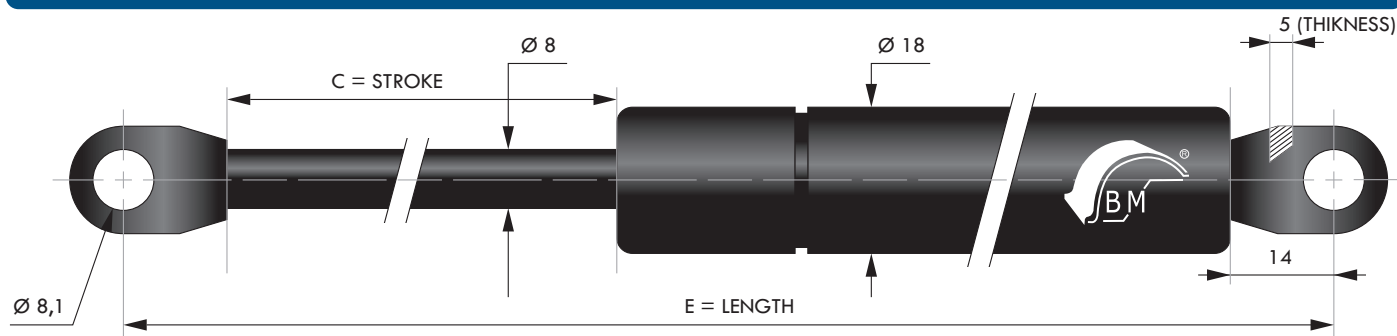

C - Stroke in mm	E - Length in mm	F1 - Force in Newtons	Reference
40	155	De 50 à 750	ST 040 + F1 + D8 E155
60	205	De 50 à 750	ST 060 + F1 + D8
72	225	De 50 à 750	ST 072 + F1 + D8
80	235	De 50 à 750	ST 080 + F1 + D8 E235
80	245	De 50 à 750	ST 080 + F1 + D8
85	275	De 50 à 750	BM 204 K
85	275	De 50 à 600	BM 204 F (diam trous 6mm)
90	255	De 50 à 750	ST 090 + F1 + D8
100	285	De 50 à 750	ST 100 + F1 + D8
120	325	De 50 à 750	ST 120 + F1 + D8
140	365	De 50 à 750	ST 140 + F1 + D8
150	385	De 50 à 750	ST 150 + F1 + D8
160	405	De 50 à 750	ST 160 + F1 + D8
180	445	De 50 à 700	ST 180 + F1 + D8
200	485	De 50 à 700	ST 200 + F1 + D8
200	485	De 50 à 700	ST 200 + F1 + D8 T6 (diam trous 6mm)
200	500	De 50 à 700	ST 200 + F1 + D8 E500
220	525	De 50 à 700	ST 220 + F1 + D8
250	585	De 50 à 700	ST 250 + F1 + D8
250	600	De 50 à 700	ST 250 + F1 + D8 E600

COMPRESSION GAS SPRINGS WITH WELDED EYES ROD 10

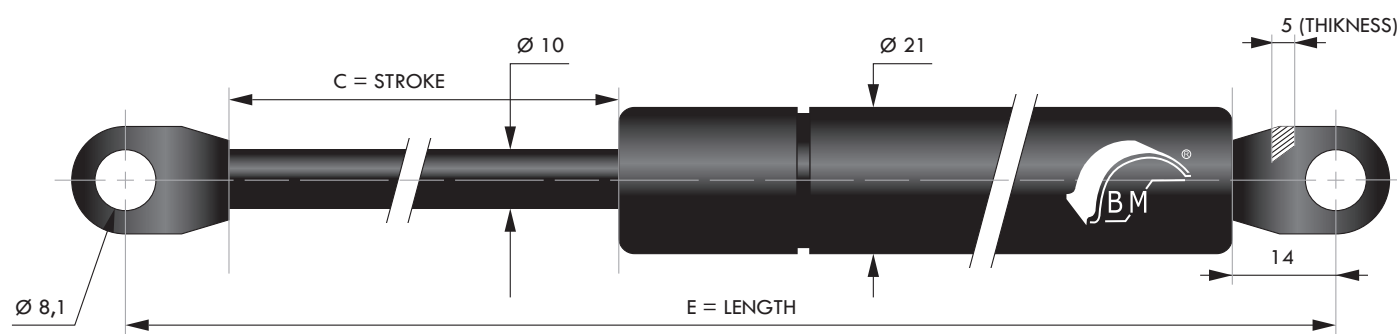

C - Stroke in mm	E - Length in mm	F1 - Force in Newtons	Référence
100	285	De 100 à 1150	ST 100 + F1 + D10
150	385	De 100 à 1150	ST 150 + F1 + D10
200	485	De 100 à 1150	ST 200 + F1 + D10
250	585	De 100 à 1050	ST 250 + F1 + D10
300	685	De 100 à 1050	ST 300 + F1 + D10
330	740	De 100 à 1050	ST 330 + F1 + D10
350	785	De 100 à 1000	ST 350 + F1 + D10
400	885	De 100 à 900	ST 400 + F1 + D10

COMPRESSION GAS SPRINGS WITH M6 THREADED ENDS DIAMETER ROD 6

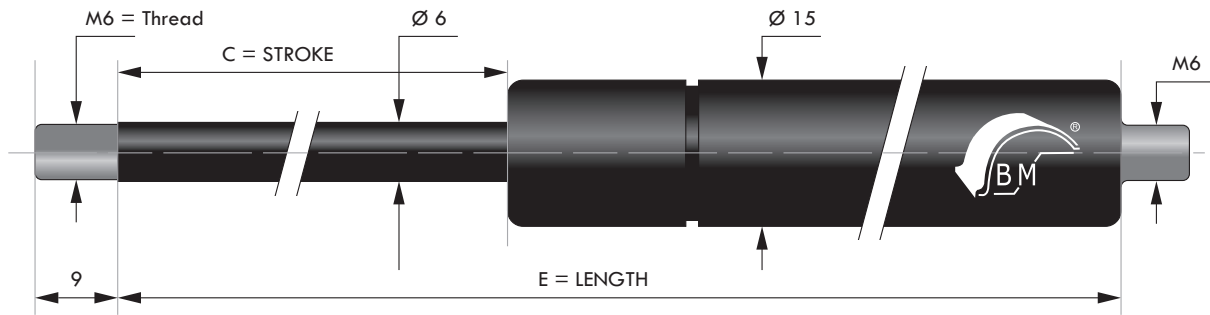

C - Stroke in mm	E - Length in mm	F1 - Force in Newtons	Reference
20	80	De 30 à 250	ST 020+F1 V+D6
40	115	De 30 à 400	ST 040+F1 V+D6
60	155	De 30 à 400	ST 060+F1 V+D6
80	195	De 30 à 400	ST 080+F1 V+D6
100	225	De 30 à 400	ST 100+F1 V+D6 E225
100	235	De 30 à 400	ST 100+F1 V+D6
120	275	De 30 à 400	ST 120+F1 V+D6
150	335	De 30 à 400	ST 150+F1 V+D6

COMPRESSION GAS SPRINGS WITH M6 THREADED ENDS DIAMETER ROD 8

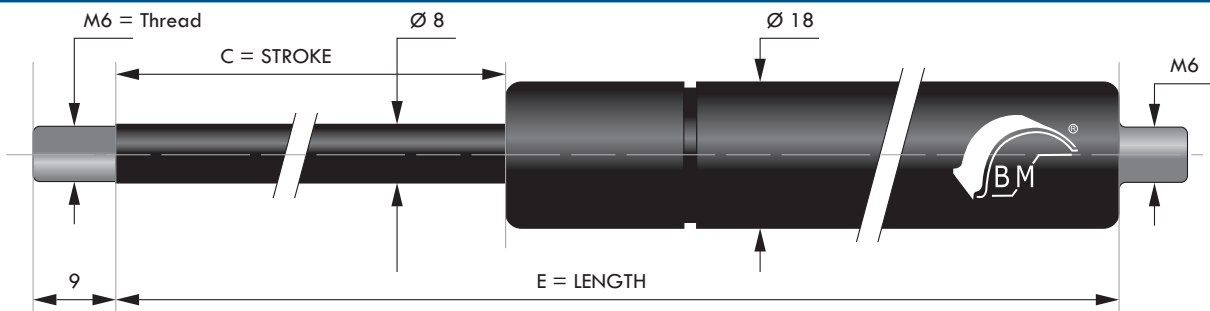

C - Stroke in mm	E - Length in mm	Valve	F1 - Force in Newtons	Reference
40	125		De 50 à 750	ST 040 + F1 V + D8
60	165		De 50 à 750	ST 060 + F1 V + D8
70	183		De 50 à 750	ST 070 + F1 V + D8
80	205		De 50 à 750	ST 080 + F1 V + D8
89	268		De 50 à 750	ST 089 + F1 V + D8
90	225		De 50 à 750	ST 090 + F1 V + D8 M8
90	225		De 50 à 750	ST 090 + F1 V + D8 M6
100	245		De 50 à 750	ST 100 + F1 V + D8
120	285		De 50 à 750	ST 120 + F1 V + D8
120	285	X	De 50 à 750	ST 120 + F1V + D8 VA
140	325		De 50 à 750	ST 140 + F1 V + D8
140	325	X	De 50 à 750	ST 140 + F1V + D8 VA
150	345		De 50 à 750	ST SP 48
160	365		De 50 à 750	ST 160 + F1 V + D8
180	405		De 50 à 700	ST 180 + F1 V + D8
180	405	X	De 50 à 700	ST 180 + F1 V + D8 VA
200	445		De 50 à 700	ST 200 + F1 V + D8
200	445	X	De 50 à 700	ST 200 + F1 V + D8 VA
210	455		De 50 à 700	ST 210 + F1 V + D8 M6-M8
220	485		De 50 à 700	ST 220 + F1 V + D8
250	545		De 50 à 700	ST 250 + F1 V + D8
250	545	X	De 50 à 700	ST 250 + F1 V + D8 VA
250	600		De 50 à 700	ST 250 + F1 V + D8E600
300	645		De 50 à 500	ST SP 25C



DELIVERY WITHIN 24 TO 48H

M6 FITTINGS

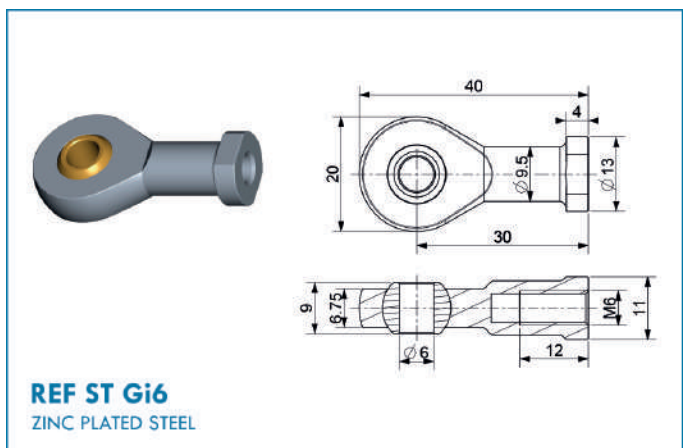
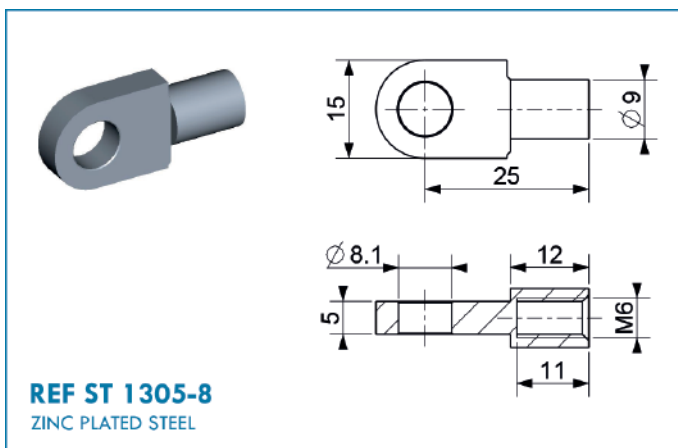
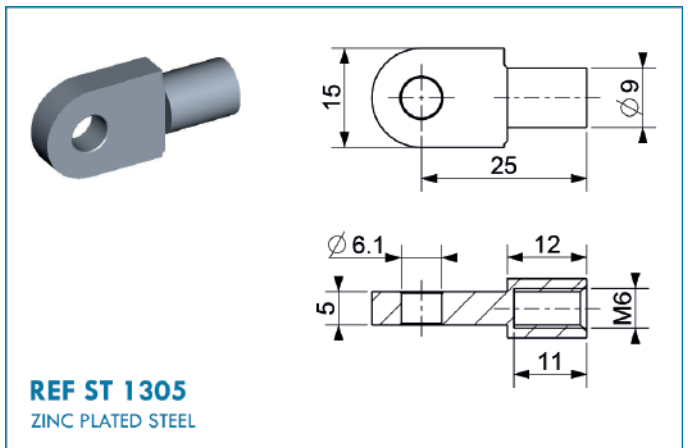
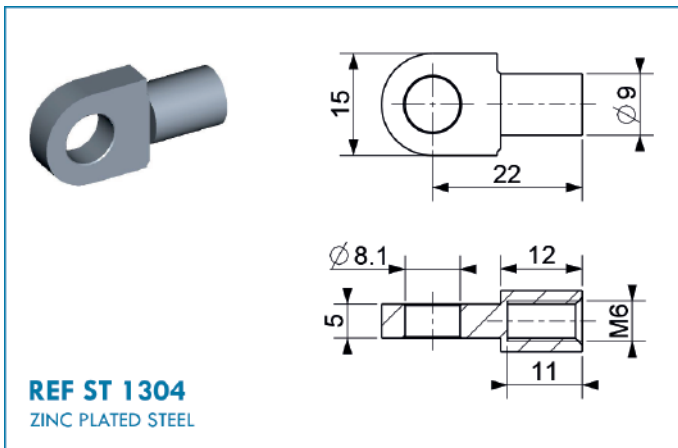
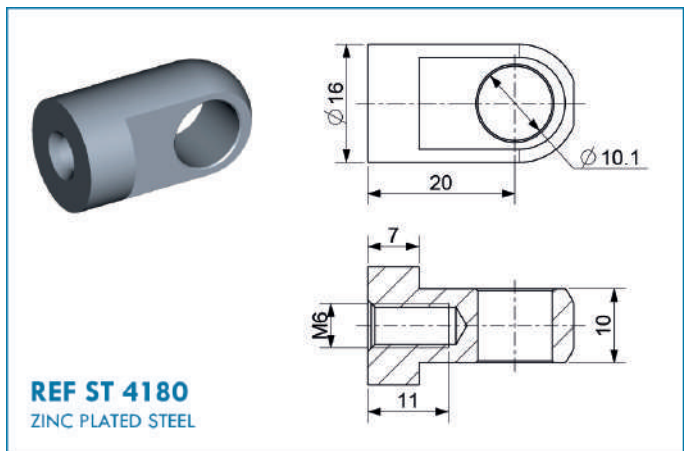
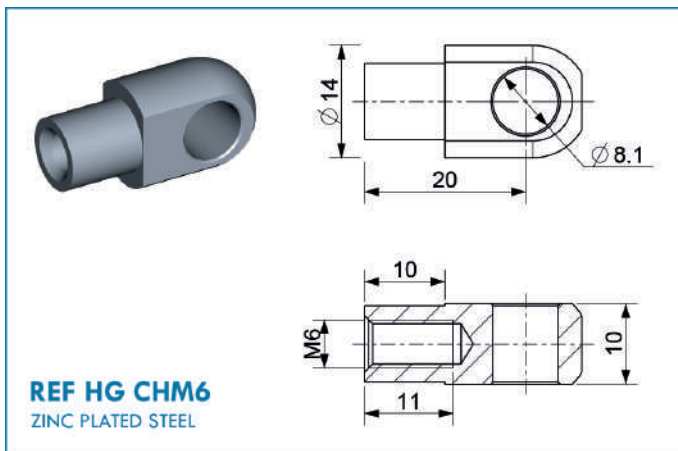
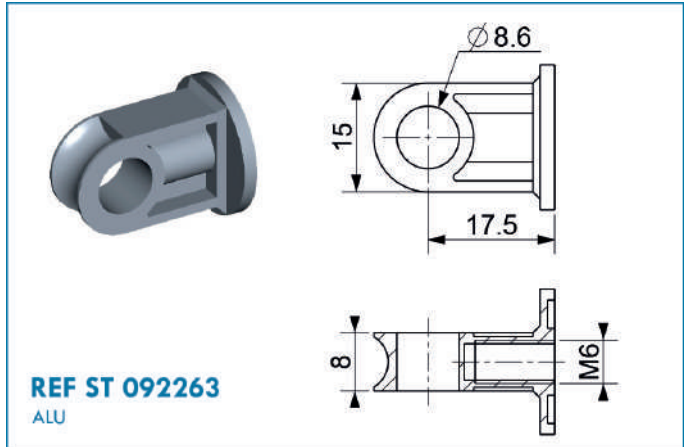
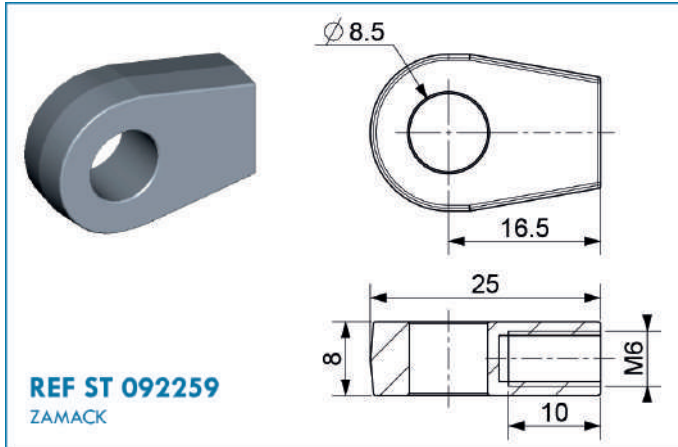

M6 FITTINGS

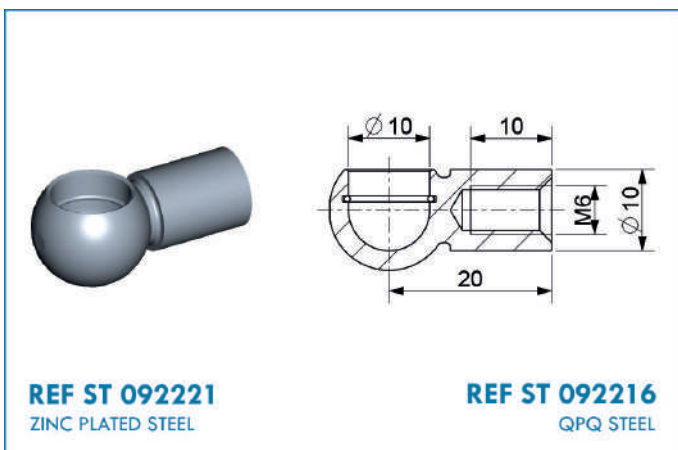
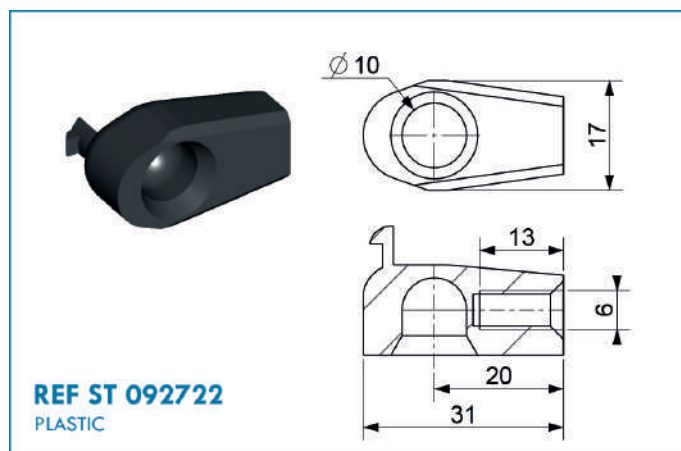
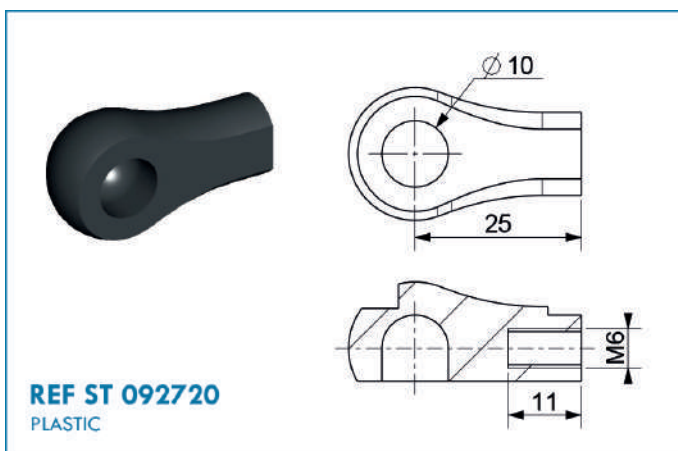
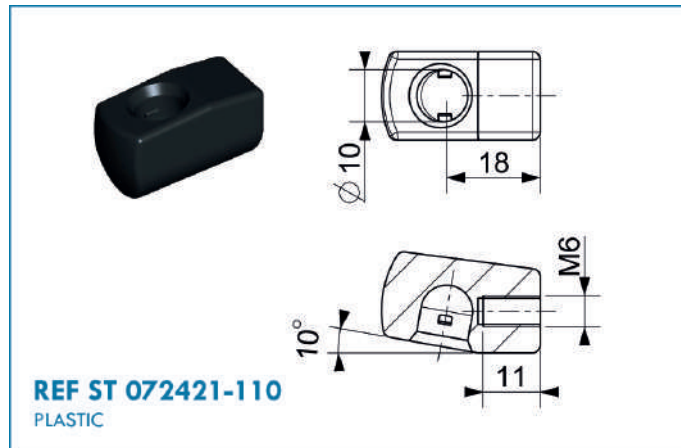
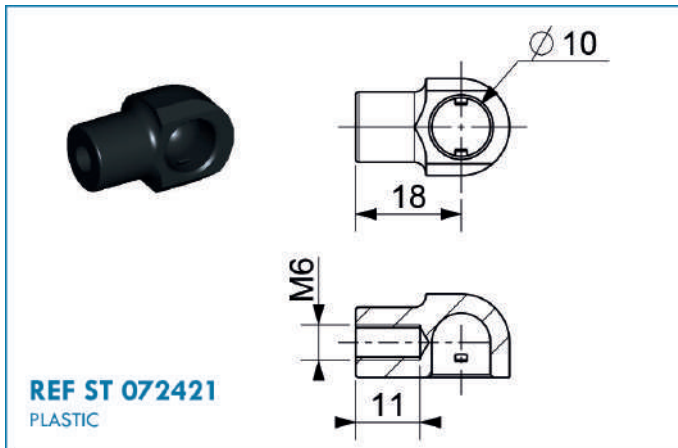

REF ST 092216
QPQ STEEL

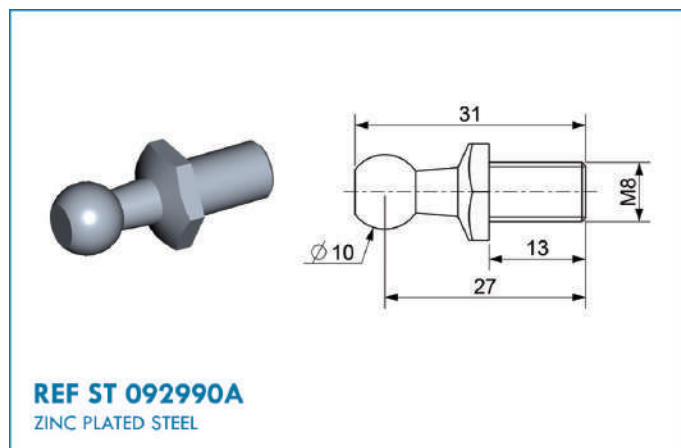
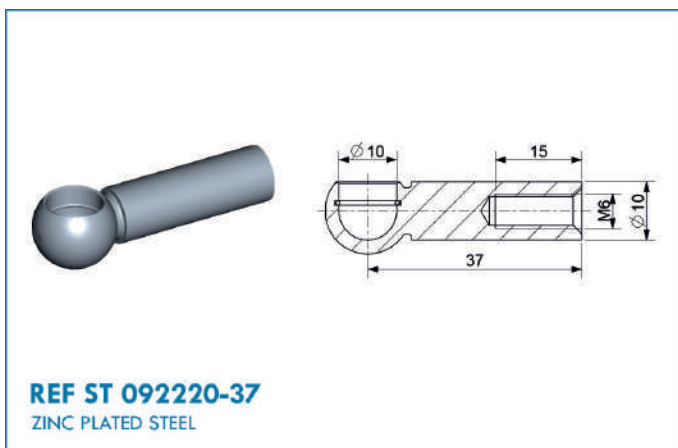
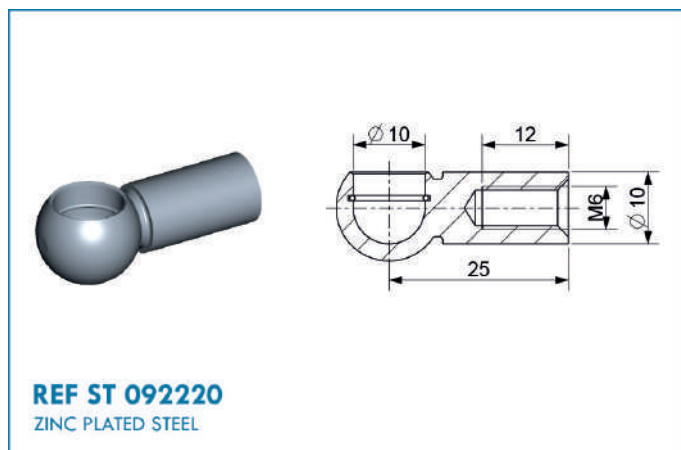

M6 FITTINGS

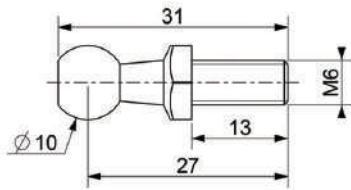

REF ST 092989
ZINC PLATED STEEL

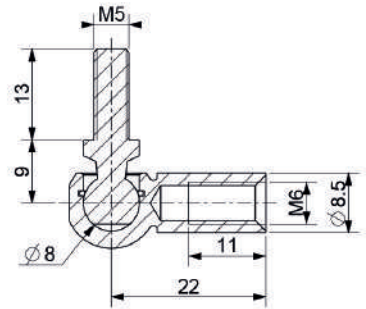
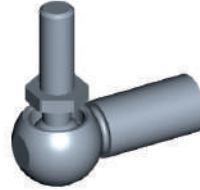

REF ST 092220-6-5
ZINC PLATED STEEL

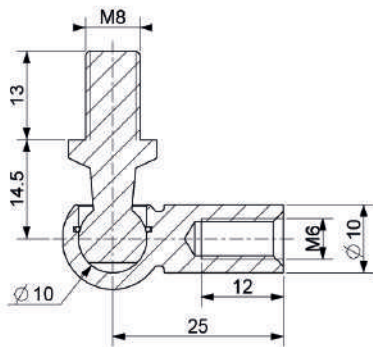

REF ST 092220-10E
ZINC PLATED STEEL

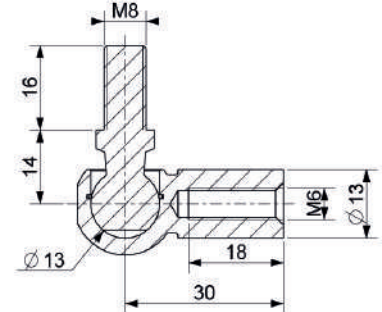
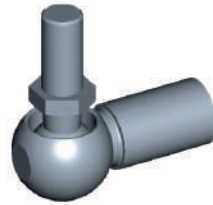

REF ST 092220-13E
ZINC PLATED STEEL

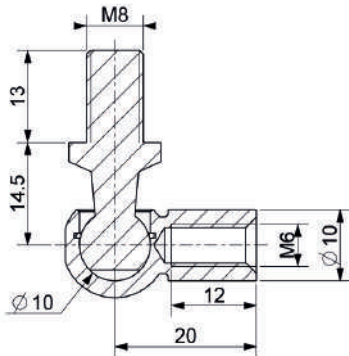
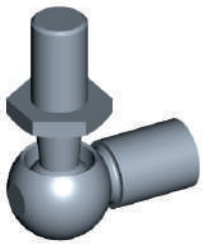

REF ST 092221-10E
ZINC PLATED STEEL

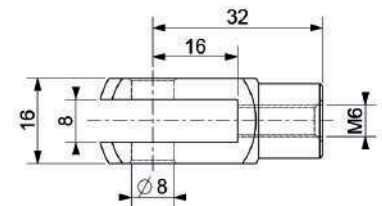

REF ST F8M6*
ZINC PLATED STEEL

*axe ST ES8 page 17

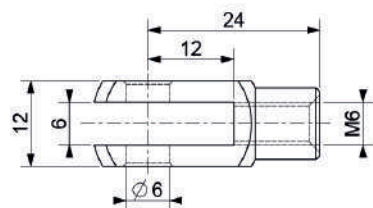

REF ST F6
ZINC PLATED STEEL

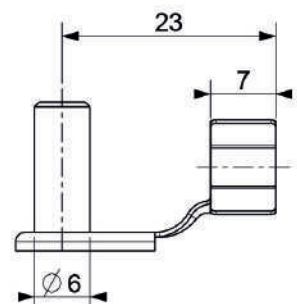
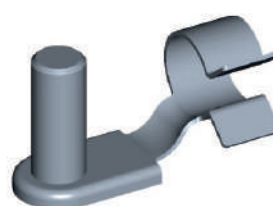

REF ST ES6
ZINC PLATED STEEL

COMPRESSION GAS SPRINGS WITH M8 THEADED ENDS DIAMETER ROD 10

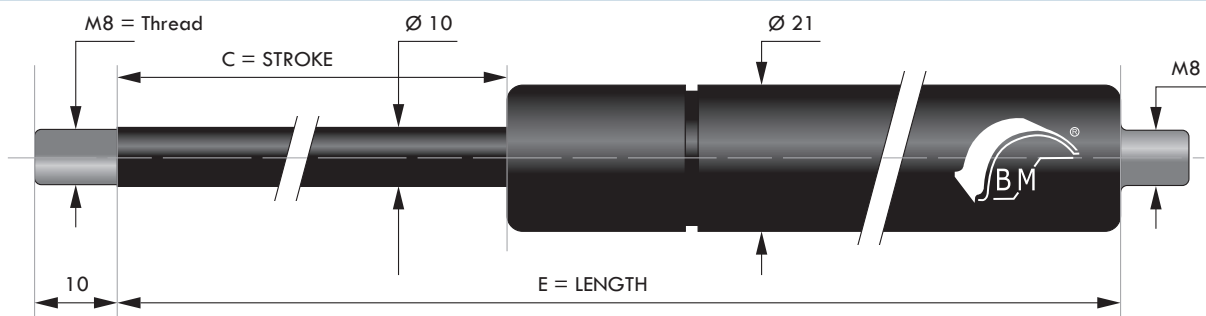

C - Stroke in mm	E - Length in mm	Valve	F1 - Force in Newtons	Reference
60	180		De 100 à 1150	ST 060 + F1 V + D10
100	255		De 100 à 1150	ST 100 + F1 V + D10
115	275		De 100 à 1150	ST 115 + F1 V + D10
150	355		De 100 à 1150	ST 150 + F1 V + D10
150	405		De 250 à 1150	ST 150 + F1 V + D10 E405
200	455		De 100 à 1150	ST 200 + F1 V + D10
200	455	X	De 100 à 1150	ST 200 + F1 V + D10 VA
250	555		De 100 à 1050	ST 250 + F1 V + D10
250	555		De 100 à 1050	ST 250 + F1 V + D10VA
250	610		De 100 à 1050	ST 250 + F1 V + D10 E610
300	655		De 100 à 1050	ST 300 + F1 V + D10
300	655	X	De 100 à 1050	ST 300 + F1 V + D10VA
300	711		De 100 à 1050	ST 300 + F1 V + D10 E711
350	735		De 100 à 1000	ST 350 + F1 + V D10 E735
350	755		De 100 à 1000	ST 350 + F1 V + D10
350	755	X	De 100 à 1000	ST 350 + F1 V + D10VA
400	855		De 100 à 900	ST 400 + F1 V + D10
400	855	X	De 100 à 900	ST 400 + F1 V + D10VA
440	960		De 100 à 900	ST 440+F1 V+D10 E960
500	1055		De 100 à 700	ST 500 + F1 V +D10
500	1055	X	De 100 à 700	ST 500 + F1 V +D10VA
550	1155	X	De 100 à 700	ST 550 + F1 V +D10VA *
600	1255	X	De 100 à 700	ST 600 + F1 V +D10VA *
650	1355	X	De 100 à 700	ST 650 + F1 V +D10VA *
700	1455	X	De 100 à 700	ST 700 + F1 V +D10VA *

* For strokes from 550 to 700 mm, the tube diameter is 22 mm

COMPRESSION GAS SPRINGS WITH M8 THEADED ENDS DIAMETER ROD 14

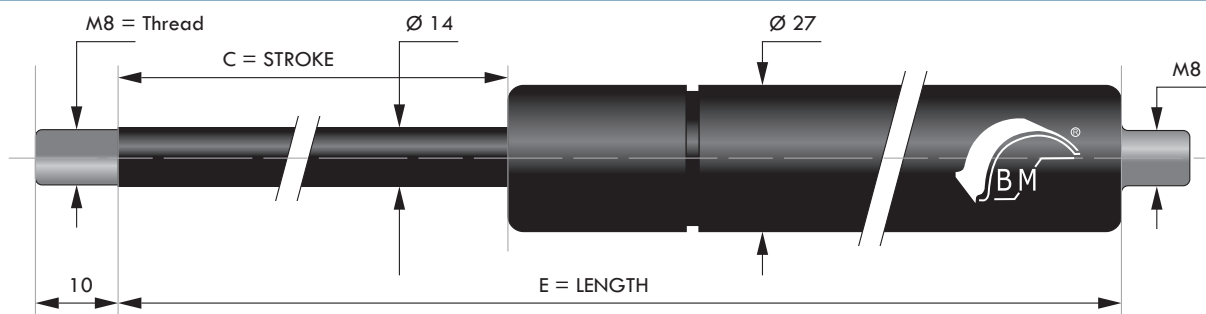

C - Stroke in mm	E - Length in mm	Valve	F1 - Force in Newtons	Reference
60	180		De 100 à 2100	ST 060 + F1 V + D14
100	255		De 100 à 2100	ST 100 + F1 V + D14
150	355		De 200 à 2100	ST 150 + F1 V + D14
200	455		De 200 à 2100	ST 200 + F1 V + D14
250	555		De 300 à 2100	ST 250 + F1 V + D14
300	655		De 300 à 2100	ST 300 + F1 V + D14
300	655	X	De 300 à 2100	ST 300 + F1 V + D14VA
350	755		De 300 à 2100	ST 350 + F1 V + D14
400	855		De 300 à 2100	ST 400 + F1 V + D14
450	955		De 300 à 2100	ST 450 + F1 V + D14
450	955	X	De 300 à 2100	ST 450 + F1 V + D14VA
500	1055		De 300 à 2100	ST 500 + F1 V + D14

M8 STANDARD ACCESSORIES

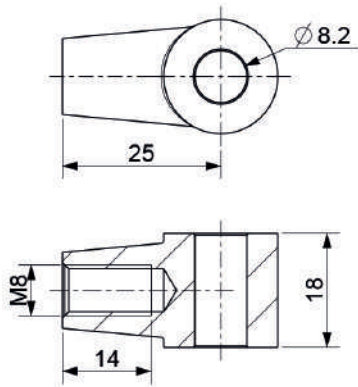

REF ST 092260
ZAMACK

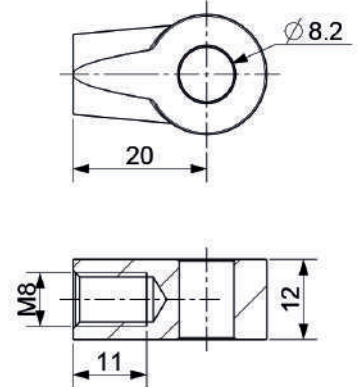

REF ST 092261
ZAMACK

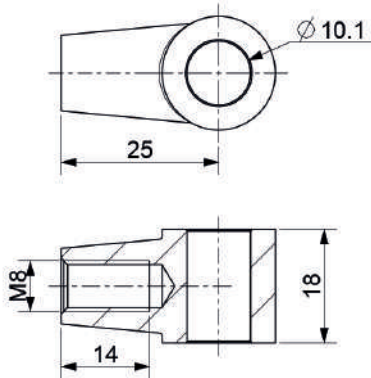

REF ST 092266
ZAMACK

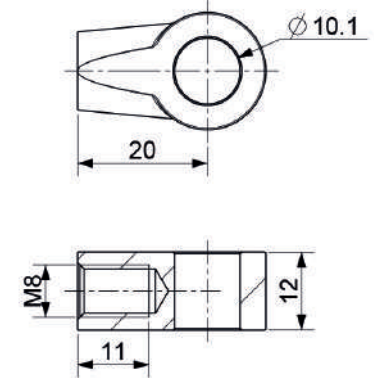

REF ST 092267
ZAMACK

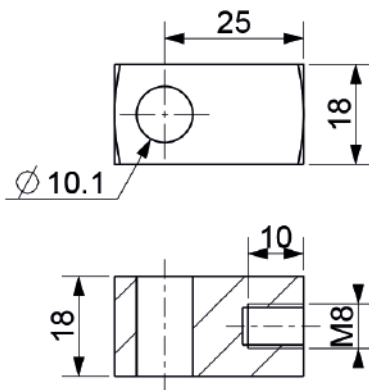
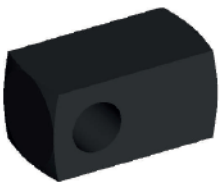

REF ST 092266N
QPQ STEEL

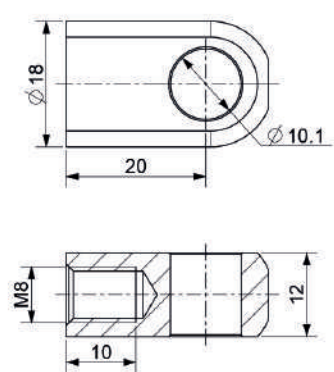

REF ST 092267AC
ZINC PLATED STEEL

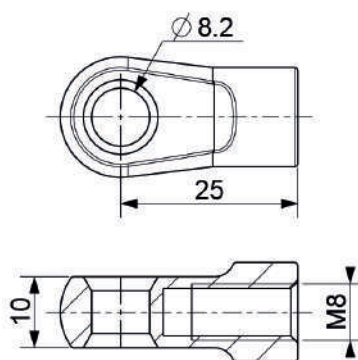

REF ST 092264
ZAMACK

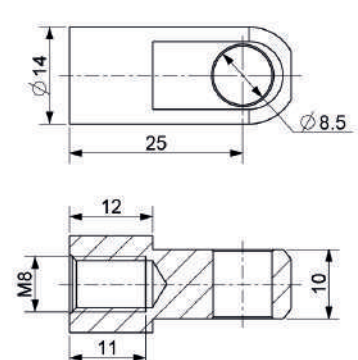

REF ST 092264AC
ZINC PLATED STEEL

M8 STANDARD ACCESSORIES

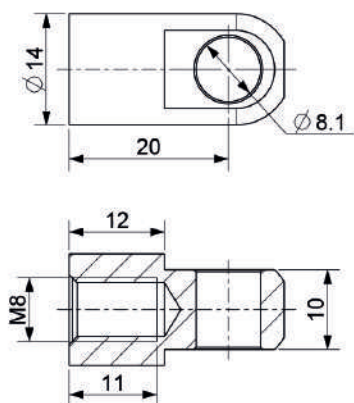

REF HG CH
ZINC PLATED STEEL

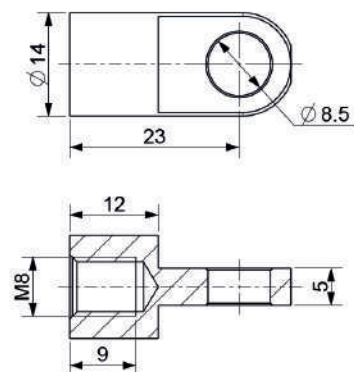
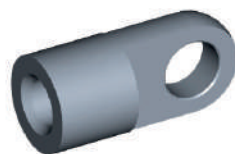

REF HG 201
ZINC PLATED STEEL

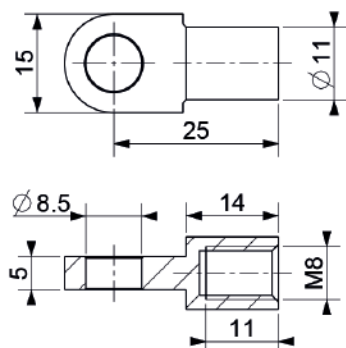

REF HG 092216
QPQ STEEL

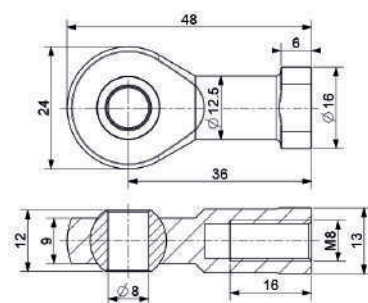
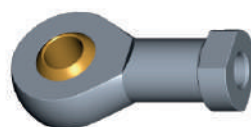

REF ST Gi8
ZINC PLATED STEEL

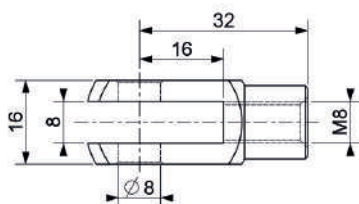
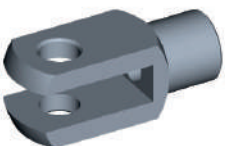

REF ST F8
ZINC PLATED STEEL

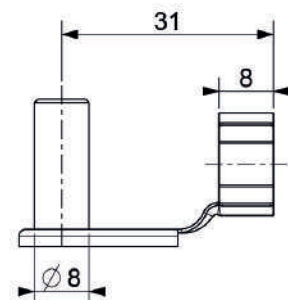
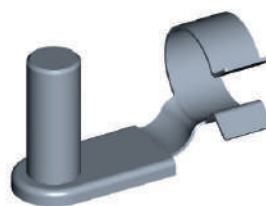

REF ST ES8
ZINC PLATED STEEL

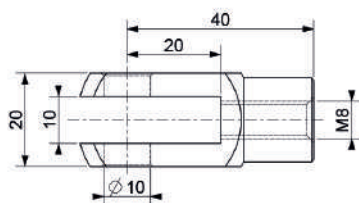
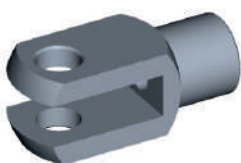

REF ST F10-8
ZINC PLATED STEEL

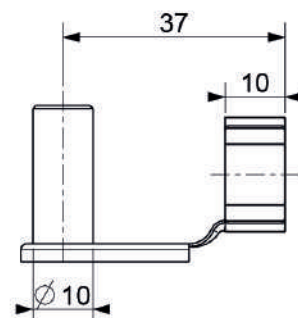
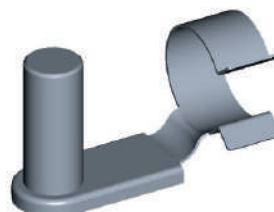

REF ST ES10
ZINC PLATED STEEL

M8 STANDARD ACCESSORIES

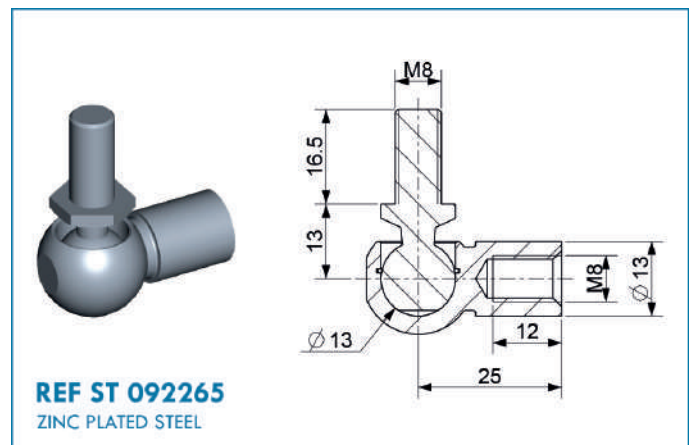
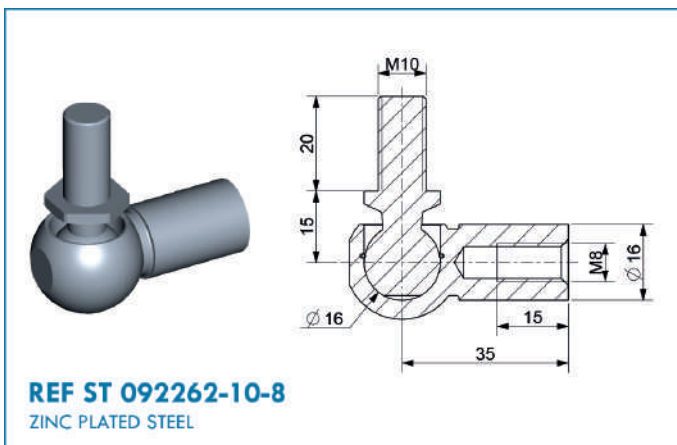
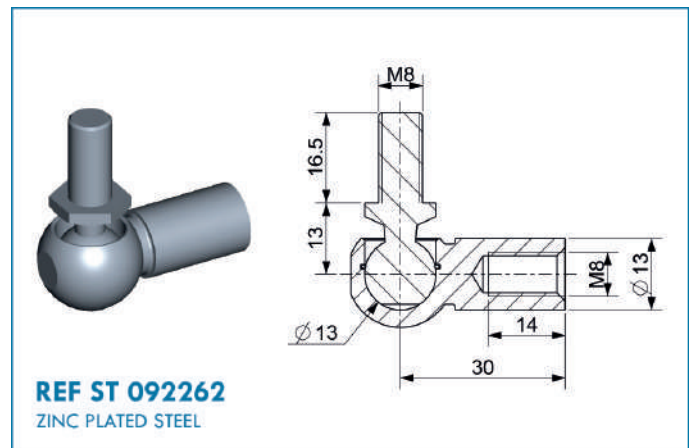
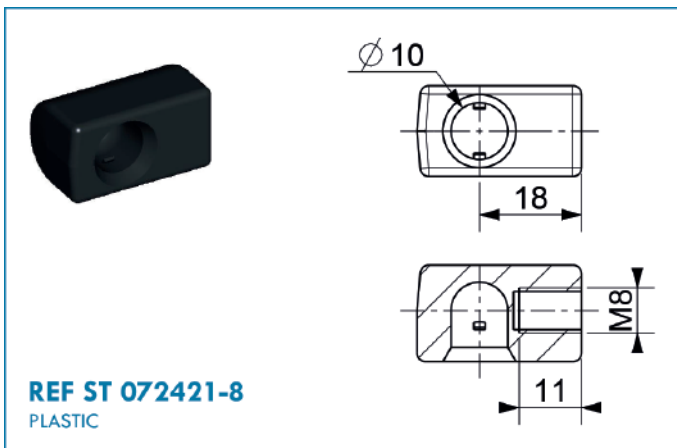
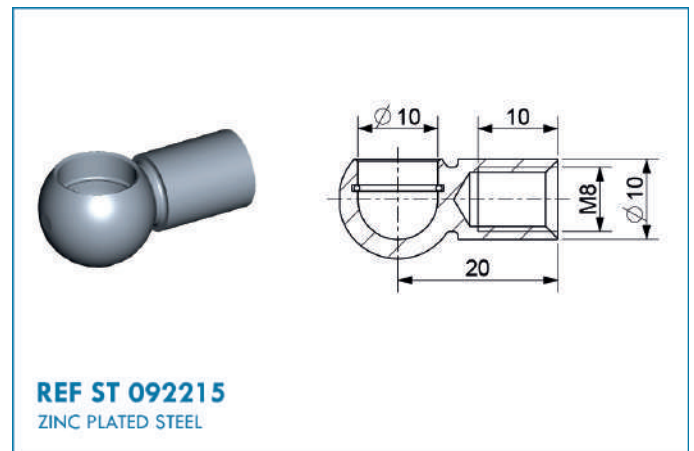
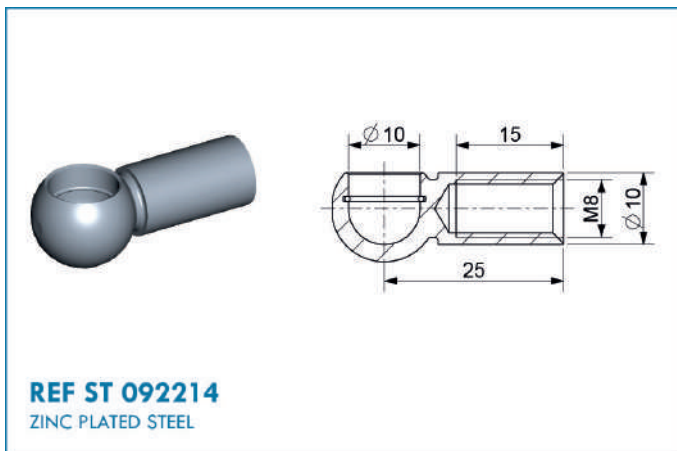
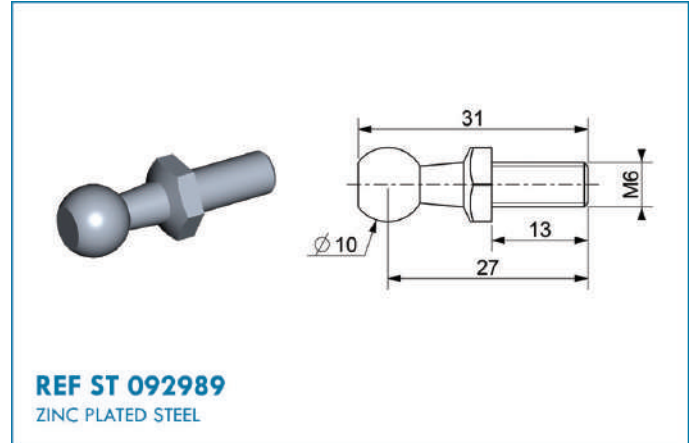
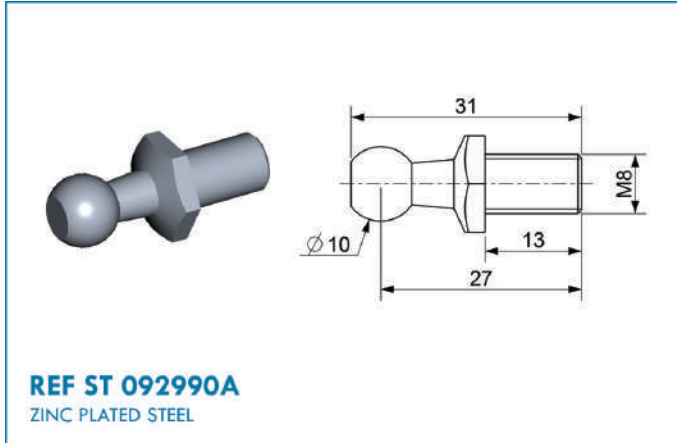

COMPRESSION GAS SPRINGS WITH M10 THEADED ENDS DIAMETER ROD 14

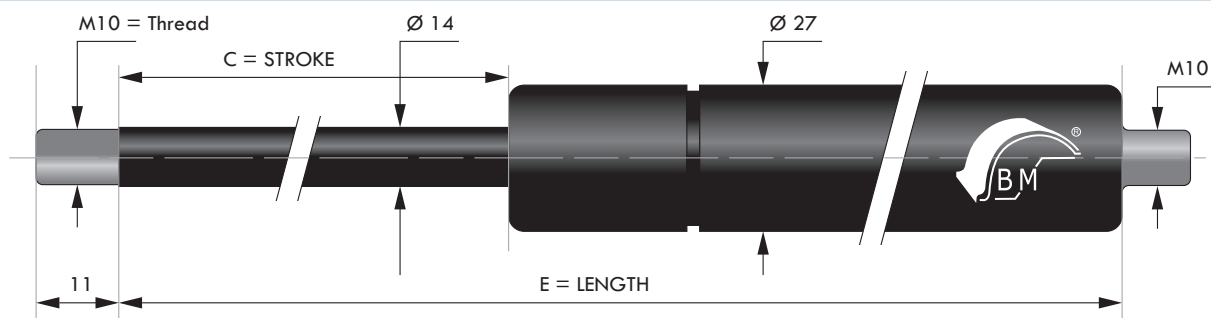

C - Stroke in mm	E - Length in mm	Valve	F1 - Force in Newtons	Reference
150	368		De 200 à 2400	ST 150 + F1 V + D14 E368 M10
200	455	X	De 200 à 2400	ST 200 + F1 V + D14 M10
250	555	X	De 300 à 2400	ST 250 + F1 V + D14 M10
300	655	X	De 300 à 2400	ST 300 + F1 V + D14 M10
350	755	X	De 300 à 2400	ST 350 + F1 V + D14 M10
400	855	X	De 300 à 2400	ST 400 + F1 V + D14 M10
450	955	X	De 300 à 2400	ST 450 + F1 V + D14 M10
500	1055		De 300 à 2100	ST 500 + F1 V + D14 M10
600	1255	X	De 300 à 2100	ST 600 + F1 V + D14 VA
650	1355	X	De 300 à 2100	ST 650 + F1 V + D14 VA
700	1455	X	De 300 à 1800	ST 700 + F1 V + D14 VA
750	1555	X	De 300 à 1800	ST 750 + F1 V + D14 VA
800	1655	X	De 300 à 1500	ST 800 + F1 V + D14 VA
900	1855	X	De 300 à 1500	ST 900 + F1 V + D14 VA

RELEASE VALVE TOOL

BM's valve tool is used to adapt a gas spring to your application, releasing the internal pressure by short presses on the tool until the desired pressure is reached. Can only be used on BM gas springs equipped with a release valve. Can only reduce pressure.

Available dimensions:

REFERENCES	THREAD VALVE
ST OUT6	M6
ST OUT8	M8
ST OUT10	M10
ST OUT14	M14



M10 STANDARD ACCESSORIES

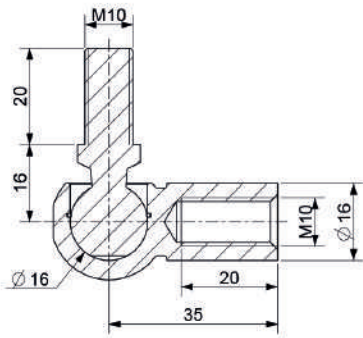

REF ST 092262-10
ZINC PLATED STEEL

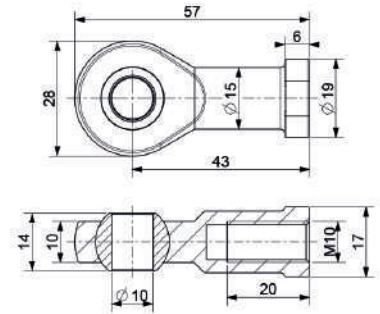
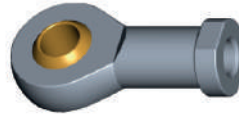

REF ST Gi10
ZINC PLATED STEEL

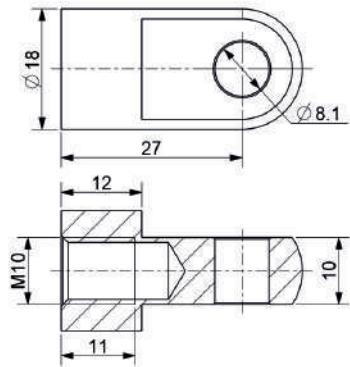

REF HG CH10
ZINC PLATED STEEL

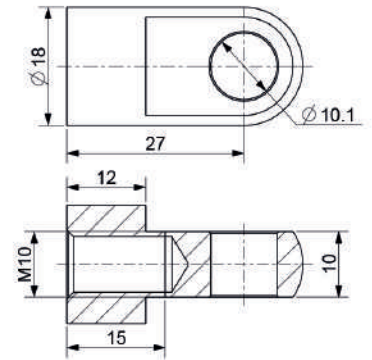

REF HG CH10-10
ZINC PLATED STEEL

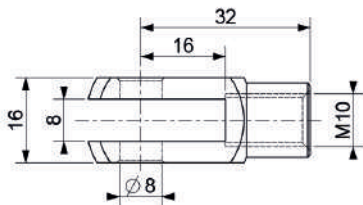

REF ST F8M10
ZINC PLATED STEEL

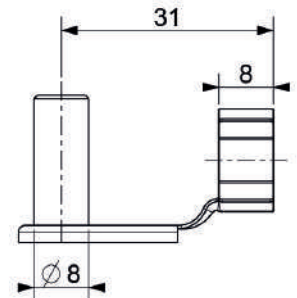
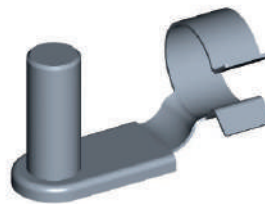

REF ST ES8
ZINC PLATED STEEL

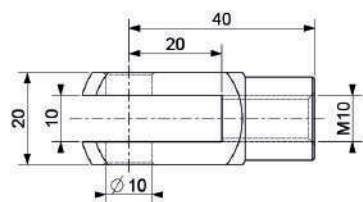
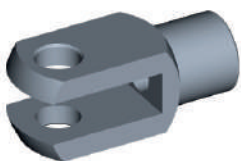

REF ST F10
ZINC PLATED STEEL

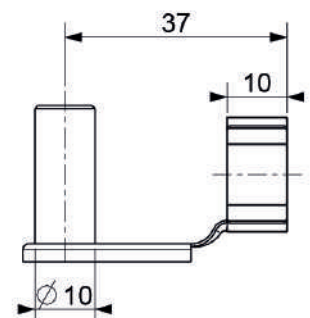
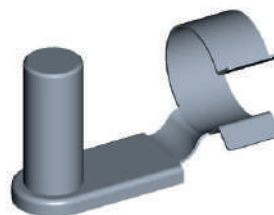

REF ST ES10
ZINC PLATED STEEL

COMPRESSION GAS SPRINGS WITH M14 TREADED ENDS DIAMETER ROD 20

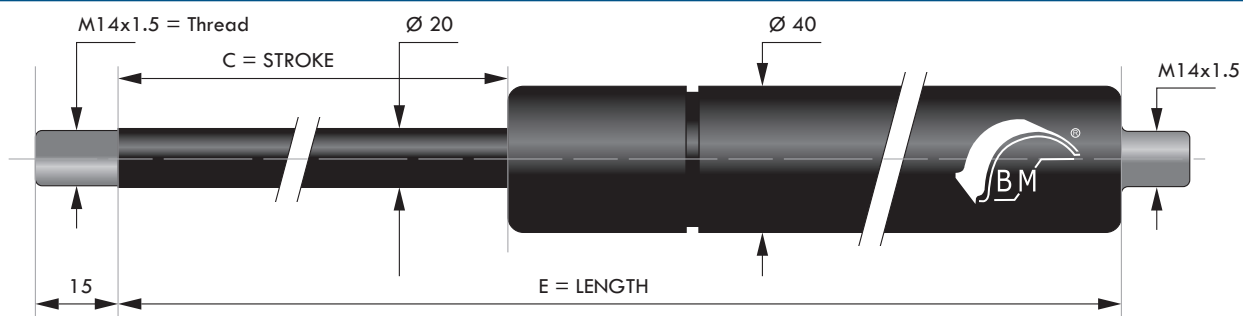

C - Stroke in mm	E - Length in mm	Valve	F1 - Force in Newtons	Reference
100	316	X	De 300 à 5200	ST 100 + F1 V + D20
150	416	X	De 300 à 5200	ST 150 + F1 V + D20
200	516	X	De 300 à 5200	ST 200 + F1 V + D20
250	616	X	De 300 à 5200	ST 250 + F1 V + D20
300	716	X	De 300 à 5200	ST 300 + F1 V + D20
350	816	X	De 300 à 5200	ST 350 + F1 V + D20
400	916	X	De 300 à 5200	ST 400 + F1 V + D20
500	1116	X	De 300 à 5200	ST 500 + F1 V + D20
600	1316	X	De 300 à 5000	ST 600 + F1 V + D20
700	1516	X	De 300 à 4000	ST 700 + F1 V + D20
800	1716	X	De 300 à 4000	ST 800 + F1 V + D20



M14 STANDARD ACCESSORIES

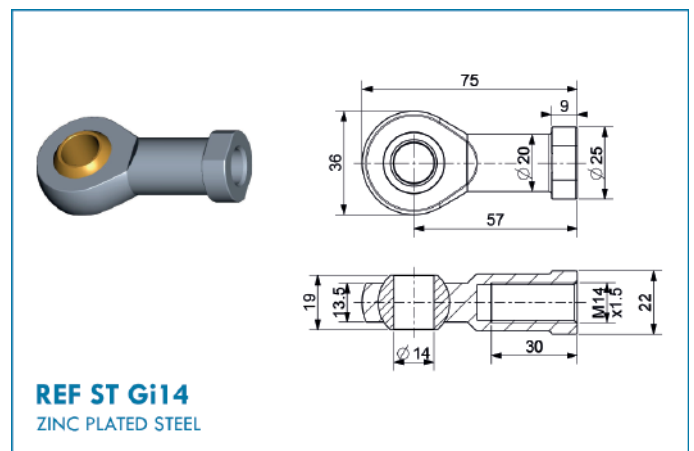
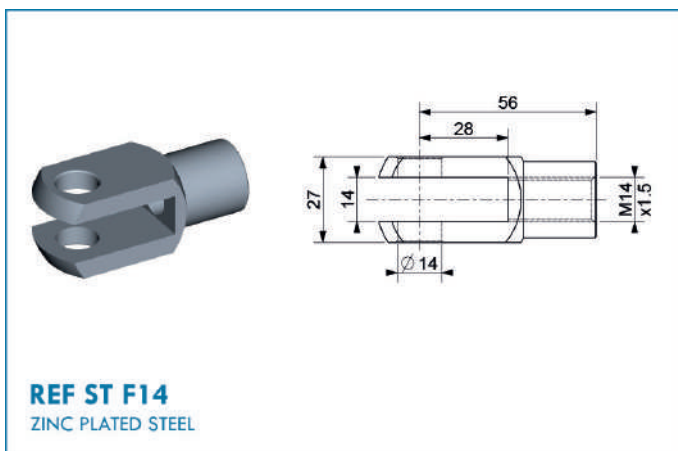
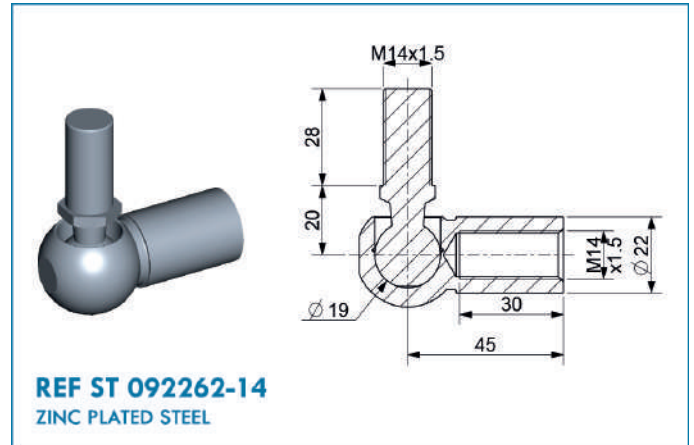
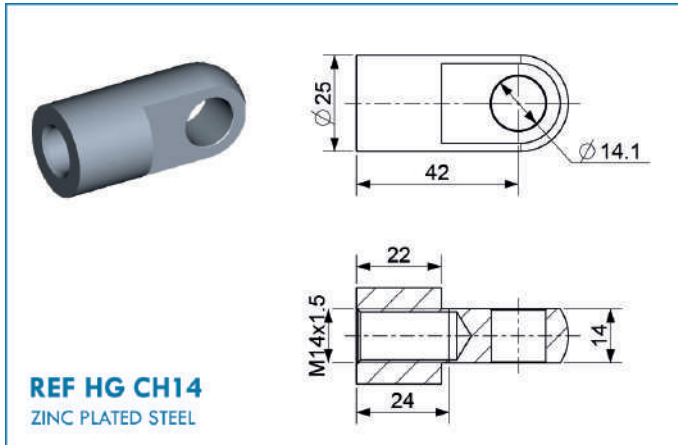

BRACKETS

With axis

REF HG 100/2
ZINC PLATED STEEL

Resistance 1800N

REF ST 092992
ZINC PLATED STEEL

Resistance 800N

With axis

REF ST P100
ALU

Resistance 800N

With axis

REF ST P100D8
ALU

Resistance 1200N

REF ST P101
ALU

Resistance 800N

REF ST P101D8
ALU

Resistance 800N

REF HG 92293
ZINC PLATED STEEL

Resistance 800N

REF HG 92293-13
ZINC PLATED STEEL

Resistance 1200N

BRACKETS

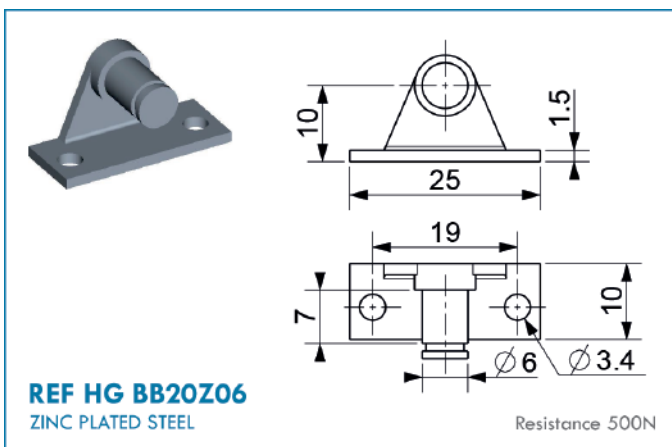
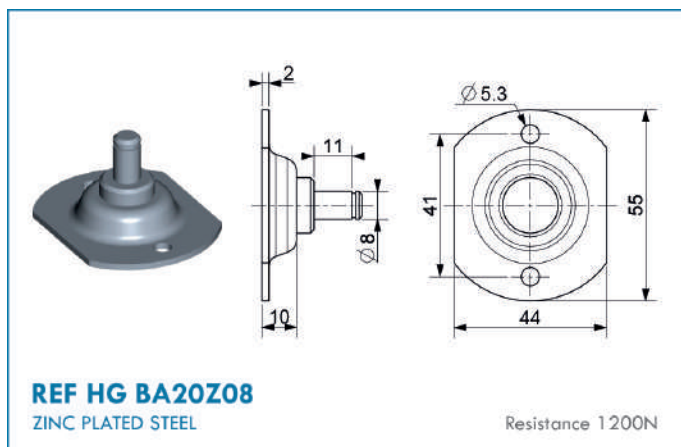
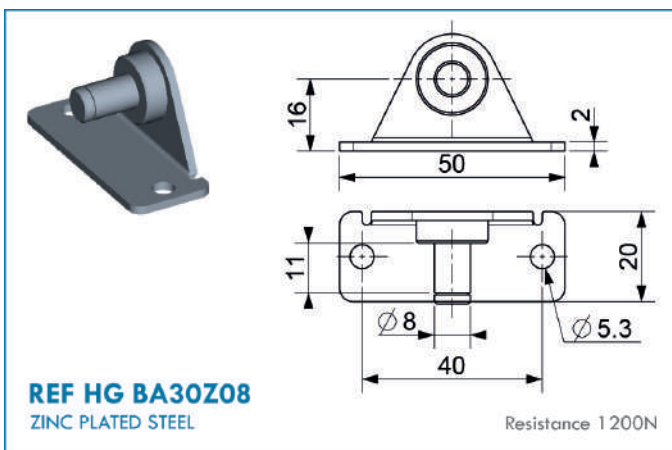
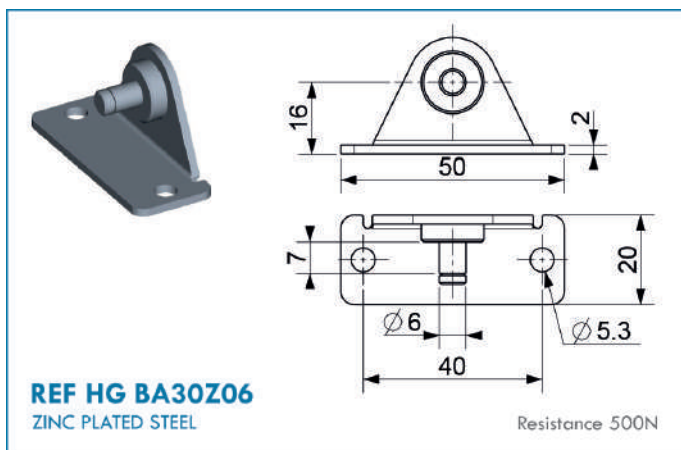
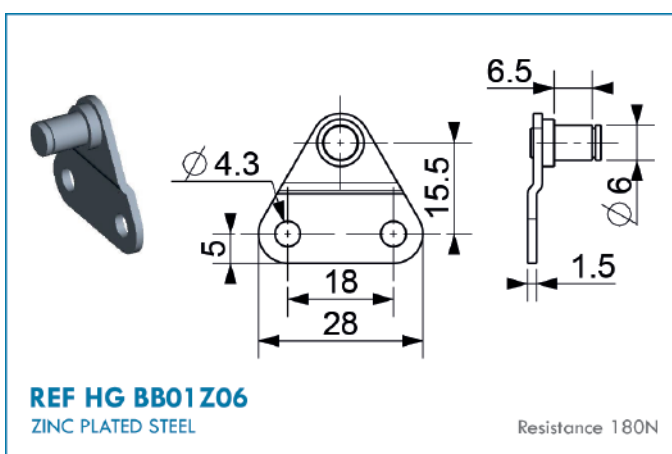
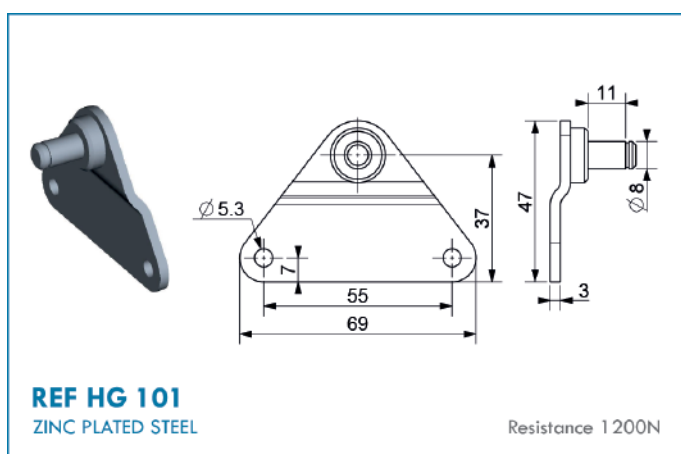
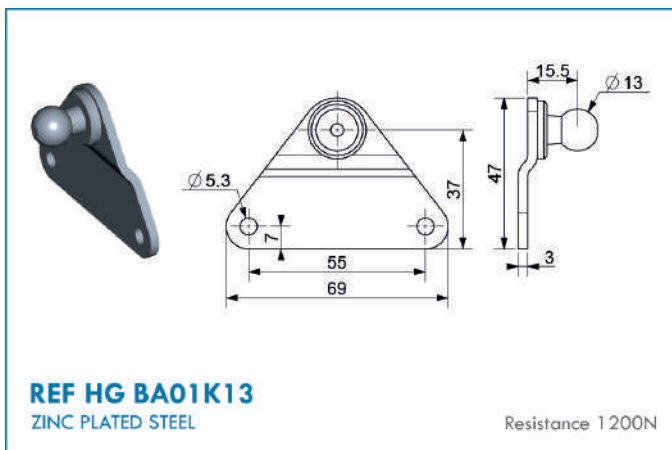
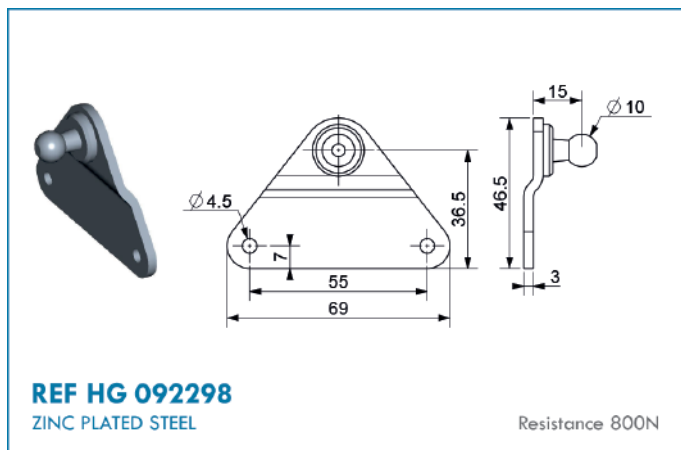

PROTECTION TUBE

Available for all BM® gas springs

Use	Protects the gas spring rod against mechanical, chemical and thermal damage. Reduce the risk of bending for long strokes.
Application	Treatment tank, manufacturing lines, polluted spaces, etc.....
Material	Steel tube
Surface	Black epoxy, galvanised or stainless steel.



WIPER RING

The new ST RAC prevents foreign matter from entering into the gas springs. Consisting of an aluminium/NBR 90sh nitrile wiper ring, and a flexible PVC cap, it effectively repulses the dirt deposited on the rod and therefore preserves the components inside the BM gas spring. Not compatible with locking tubes or protection tubes.

Requires a gas spring with threaded ends.



DIMENSIONS AVAILABLE ACCORDING TO BM STANDARDS

Dimensions	Stroke used (mm)	Force consumed (N)	Reference
6 mm Rod 15 mm Body	7	10 à 25N	ST RAC06-15
8 mm Rod 18-19 mm Body	7.5	10 à 20N	ST RAC08-19
10 mm Rod 21-23 mm Body	8	10 à 20N	ST RAC10-23
14 mm Rod 27-28 mm Body	8.5	10 à 20N	ST RAC14-28
20 mm Rod 40 mm Body	9.5	35 à 15N	ST RAC20-40



DELIVERY WITHIN 24 TO 48H

LOCKING TUBES

Tubes can be adapted to our standard threaded gas springs depending on the dimensions.

Locking tube for standard gas springs	Locking Tubes Reference
ST 160+F1 V+D8	ST TUB08160
ST 250+F1 V+D8	ST TUB08250
ST 200+F1 V+D10	ST TUB10200
ST 250+F1 V+D10	ST TUB10250
ST 300+F1 V+D10	ST TUB10300
ST 350+F1 V+D10	ST TUB10350
ST 400+F1 V+D10	ST TUB10400
ST 500+F1 V+D10	ST TUB10500
ST 200+F1 V+D14	ST TUB14200
ST 250+F1 V+D14	ST TUB14250
ST 300+F1 V+D14	ST TUB14300
ST 350+F1 V+D14	ST TUB14350
ST 400+F1 V+D14	ST TUB14400
ST 450+F1 V+D14	ST TUB14450
ST 500+F1 V+D14	ST TUB14500

This locking tube ensures the gas spring is safe in the open position.

The new universal BM locking tube secure the open position of your application by locking one of the two springs in the open position. It can be unlocked by pressing the tube. Ideal for applications requiring locking in the open position.

It can be fitted to threaded BM gas springs.

 The blocking tube leads to a loss of 20 mm of the useful stroke.

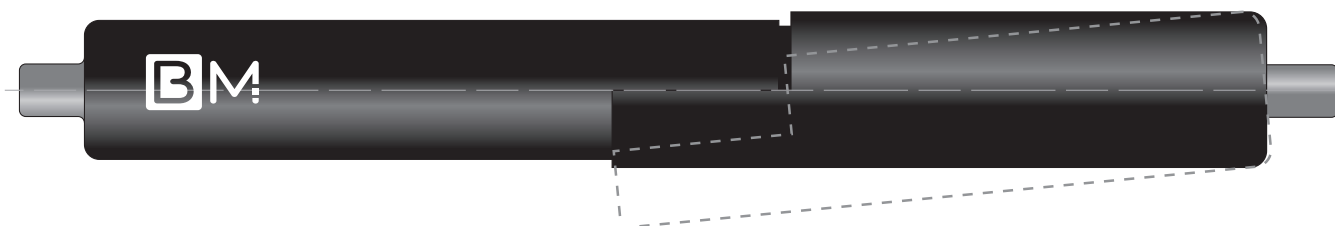

STAINLESS STEEL RANGE

Made from **316 stainless steel**, our stainless steel gas springs provide **high resistance in difficult conditions** (humidity, salty air, chemicals products, outside use, etc.) but have also a nice design looking and better performing than steel. They can enhance your products.

Made to the same dimensions as our standard steel gas springs, but all with M8 threads, they are fully compatible with everyday applications.

So upgrade your application at a competitive price with **Berthold Marx stainless steel springs!**

STAINLESS STEEL COMPRESSION GAS SPRINGS WITH M8 THREADED END DIAMETER DIAM.8

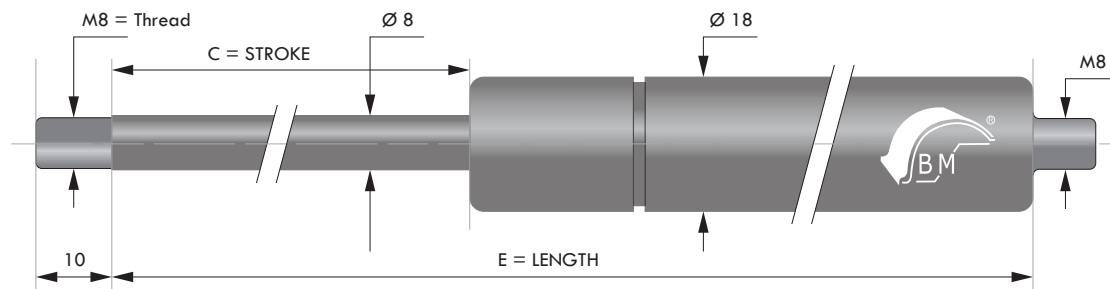

C - Stroke in mm	E - Length in mm	F1 - Force in Newtons	Reference
60	165	De 50 à 650	ST 060 + F1 V +D8iN
80	205	De 50 à 650	ST 080 + F1 V +D8iN
100	245	De 50 à 650	ST 100 + F1 V +D8iN
120	285	De 50 à 650	ST 120 + F1 V +D8iN
140	325	De 50 à 650	ST 140 + F1 V +D8iN
160	365	De 50 à 650	ST 160 + F1 V +D8iN
180	405	De 50 à 650	ST 180 + F1 V +D8iN
200	445	De 50 à 650	ST 200 + F1 V +D8iN
250	545	De 50 à 650	ST 250 + F1 V +D8iN

STAINLESS STEEL COMPRESSION SPRINGS GAS WITH M8 THREADED END DIAMETER DIAM.10

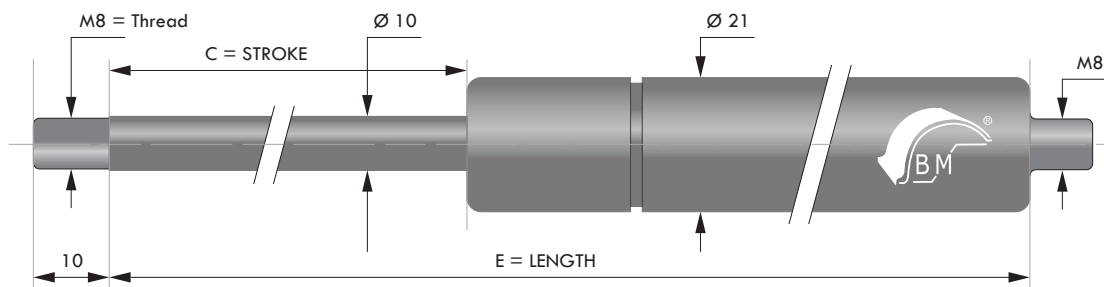

C - Stroke in mm	E - Length in mm	F1 - Force in Newtons	Reference
100	255	De 100 à 1000	ST 100 + F1 V +D10iN
150	355	De 100 à 1000	ST 150 + F1 V +D10iN
200	455	De 100 à 1000	ST 200 + F1 V +D10iN
250	555	De 100 à 1000	ST 250 + F1 V +D10iN
300	655	De 100 à 1000	ST 300 + F1 V +D10iN
350	755	De 100 à 900	ST 350 + F1 V +D10iN
400	855	De 100 à 800	ST 400 + F1 V +D10iN
500	1055	De 100 à 800	ST 500 + F1 V +D10iN



DELIVERY WITHIN 24 TO 48H

STAINLESS STEEL COMPRESSION GAS SPRINGS WITH M8 THREADED END DIAMETER DIAM.14

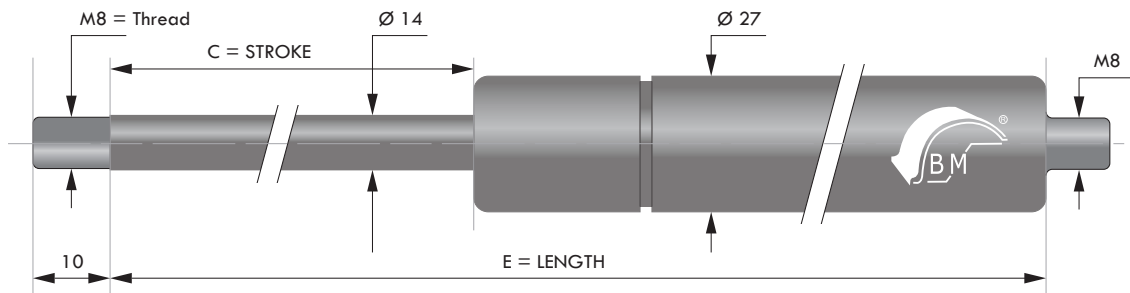

C - Stroke in mm	E - Length in mm	F1 - Force in Newtons	Reference
150	355	De 200 à 2100	ST 150 + F1 V +D14iN
200	455	De 200 à 2100	ST 200 + F1 V +D14iN
250	555	De 200 à 2100	ST 250 + F1 V +D14iN
300	655	De 200 à 2100	ST 300 + F1 V +D14iN
350	755	De 200 à 2100	ST 350 + F1 V +D14iN
400	855	De 200 à 2100	ST 400 + F1 V +D14iN
500	1055	De 200 à 2100	ST 500 + F1 V +D14iN

SPECIAL STAINLESS STEEL GAS SPRINGS

Numerous options are available on request (e.g.: Food oil, valve, etc.)

We can also make customised stainless steel gas springs in less than 5 weeks, namely:

Material :

Rod	1.4305 / AISI 303	ou	1.4404 / AISI 316L
Bodies	1.4301 / AISI 304	ou	1.4571 / AISI 316TI
End pieces	1.4305 / AISI 303	ou	1.4404 / AISI 316L

POSSIBLE DIMMENSIONS

RODS / BODIES (mm)	FORCES (N)	STROKE (mm)	304	316L
4mm / 12mm	10-180	10-200	X	X
6mm / 15mm	40-400	20-300	X	X
6mm / 19mm	40-400	20-300	X	X
8mm / 19mm	50-700	40-500	X	X
8mm / 23mm	50-700	40-500	X	X
10mm / 23mm	100-1100	40-700	X	X
10mm / 28mm	100-1100	40-700	X	X
10mm / 40mm	150-1100	30-700	X	X
14mm / 28mm	150-2100	50-700	X	X
14mm / 40mm	150-2100	50-700	X	X
20mm / 40mm	300-5000	50-600	X	X
22mm / 40mm	500-6000	50-1000	X	



STAINLESS ACCESSORIES

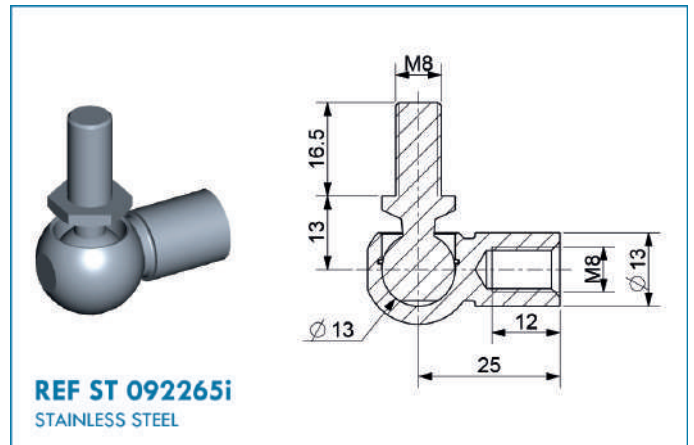
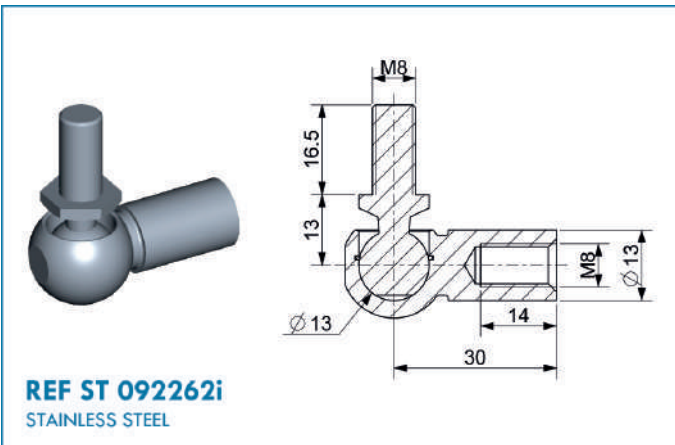
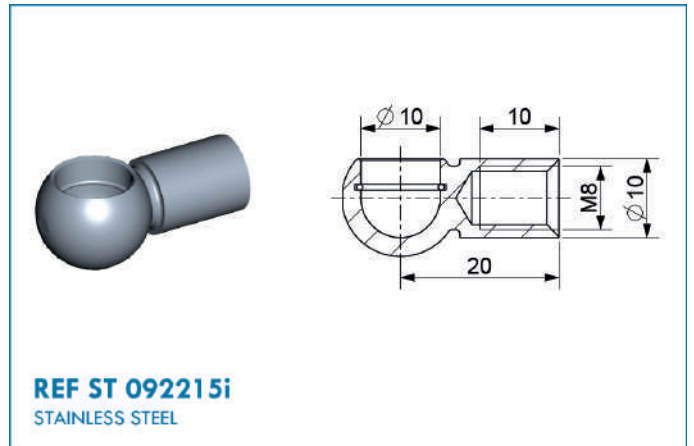
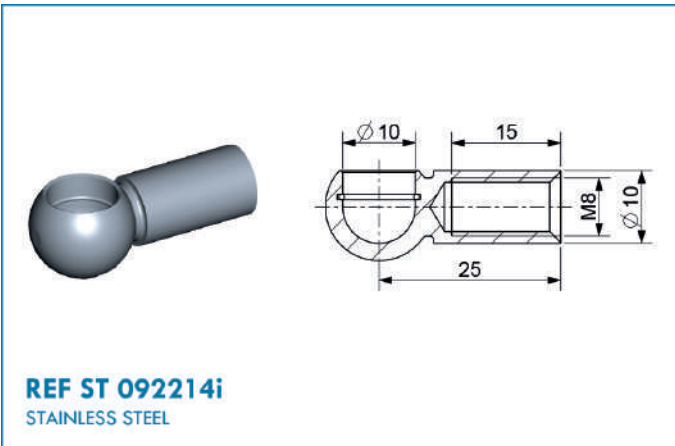
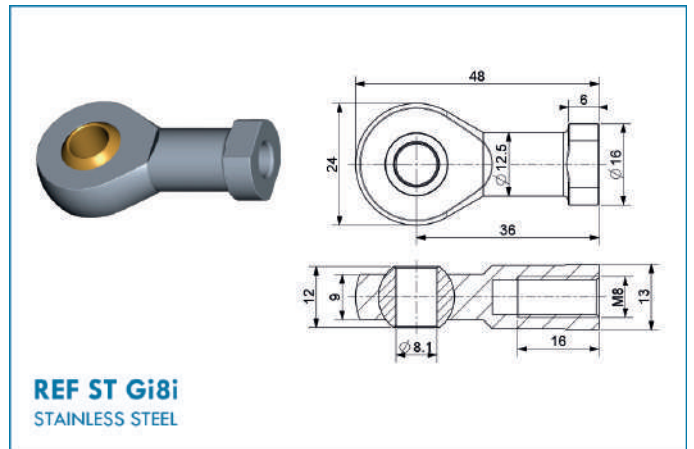
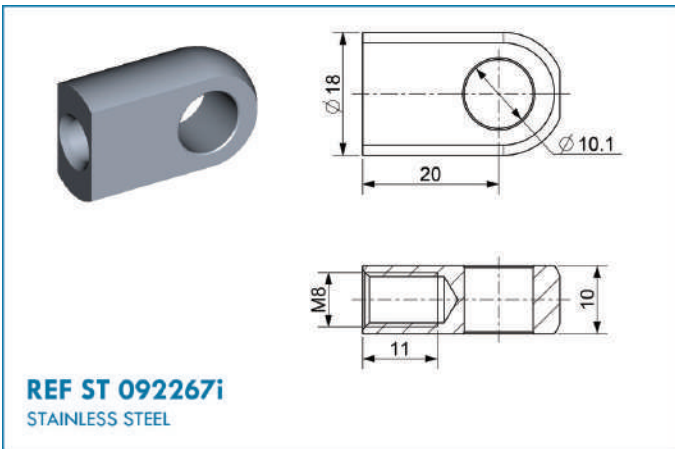
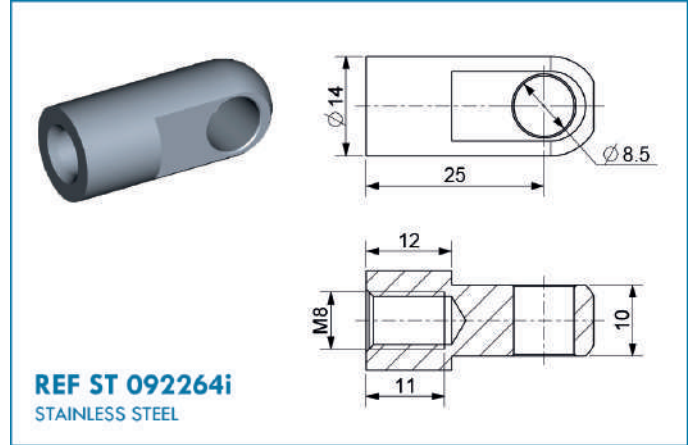
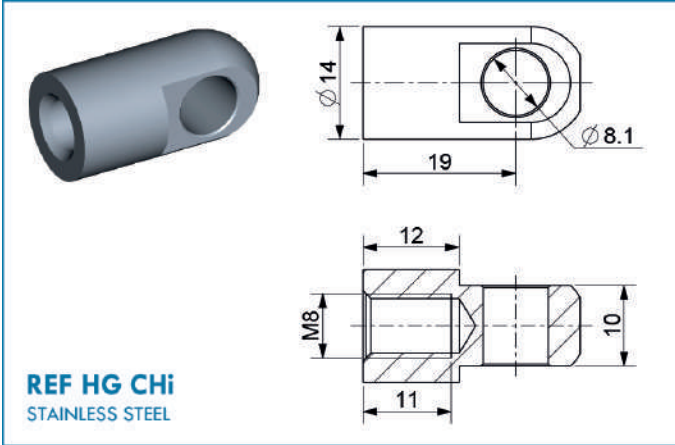

STAINLESS ACCESSORIES

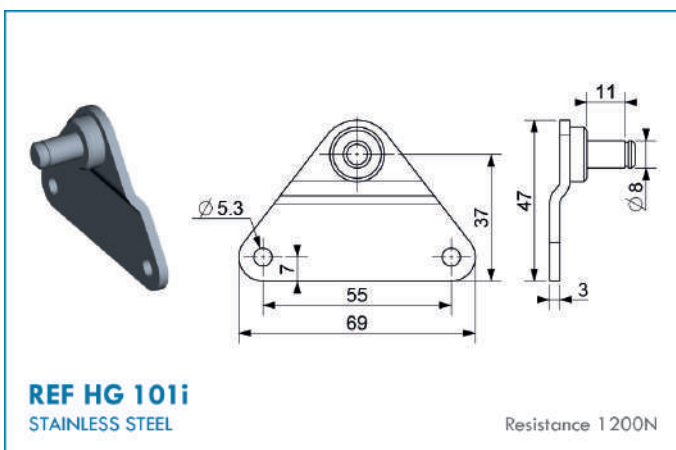
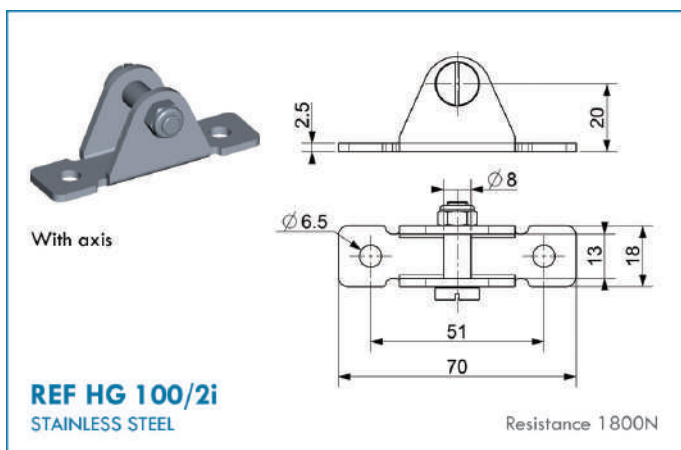
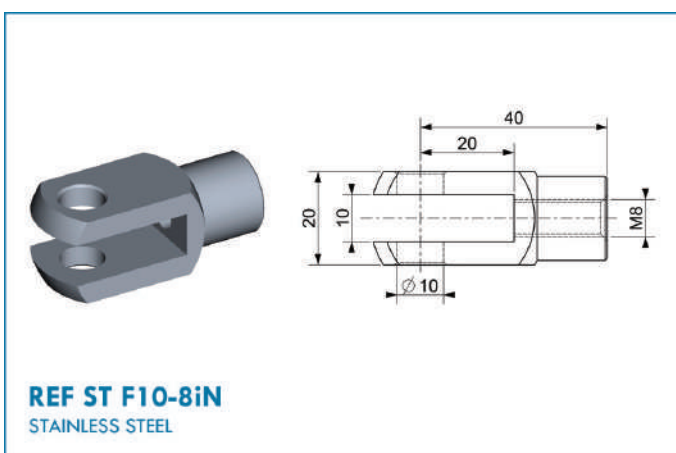
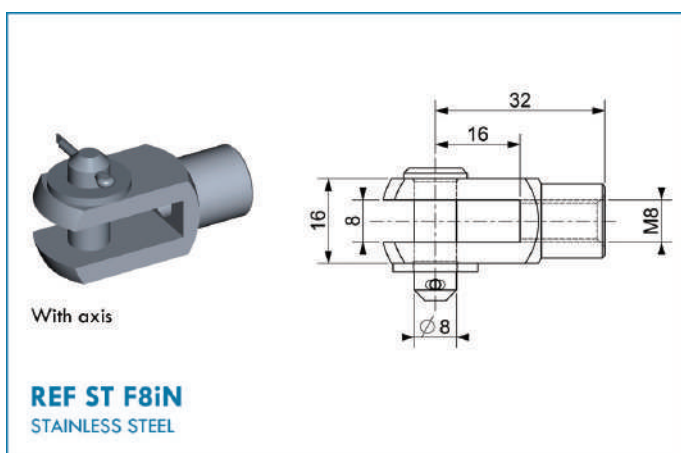
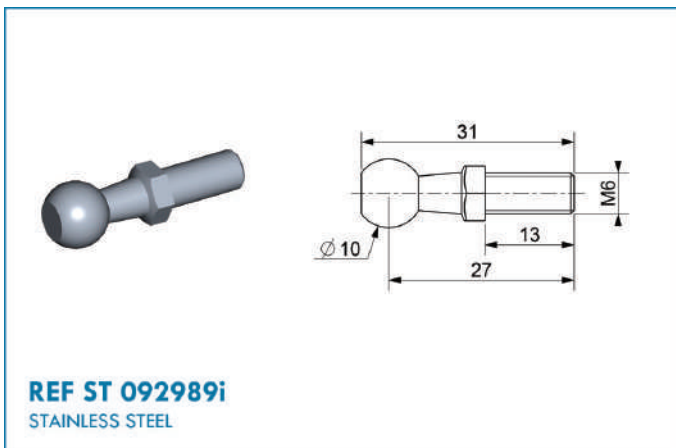
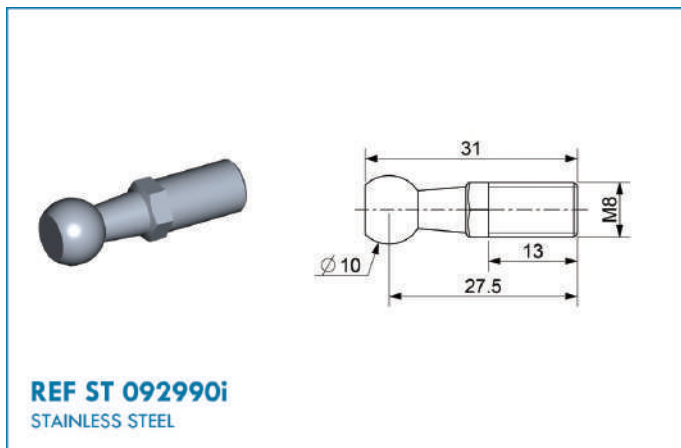

OUR TRACTION GAS SPRINGS

Traction gas springs - Diagram

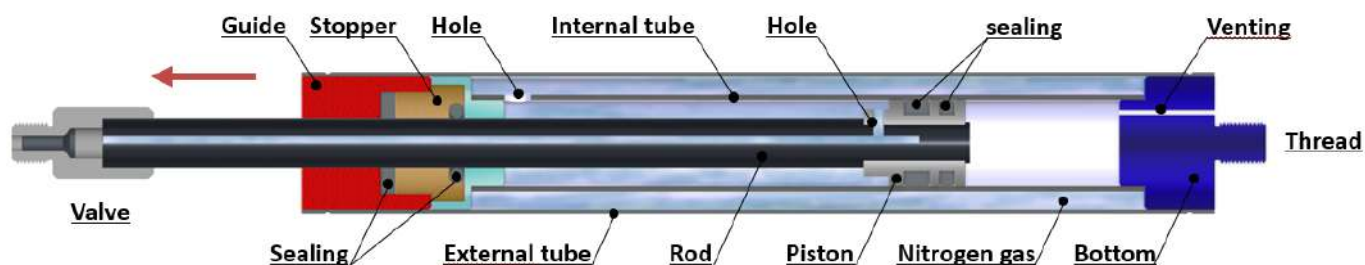

TRACTION GAS SPRINGS WITH M8 THEADED ENDS DIAMETER ROD 10

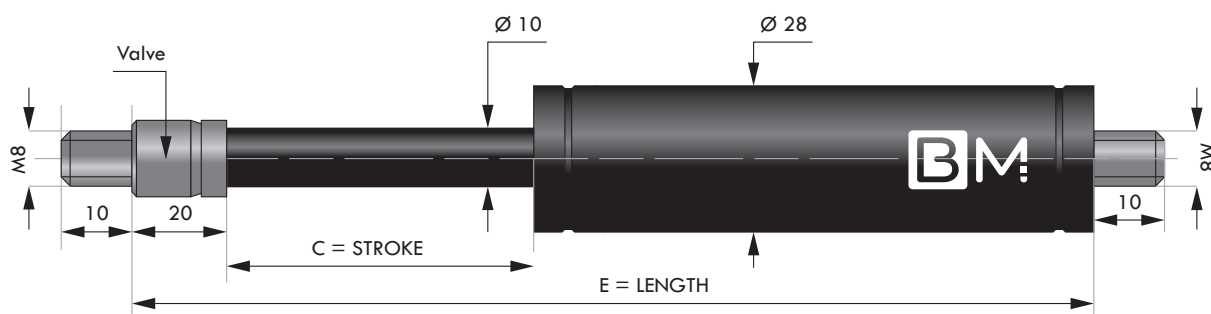

C - Stroke in mm	E - Length in mm	F1 - Force in Newtons	Reference
100	300	De 150 à 1200	ST T28 100 + F1 V
150	400	De 150 à 1200	ST T28 150 + F1 V
200	500	De 150 à 1200	ST T28 200 + F1 V
250	600	De 150 à 1200	ST T28 250 + F1 V
300	700	De 150 à 1200	ST T28 300 + F1 V
350	800	De 150 à 1200	ST T28 350 + F1 V
400	900	De 150 à 1200	ST T28 400 + F1 V

OTHER DIMENSIONS : CONTACT US

Compatible end fittings are available on pages 15, 16 et 17.

COMPRESSION AND TRACTION GAS SPRINGS CUSTOM STEEL

Berthold Marx can make customised steel Gas Springs within 5 weeks:

Material :	Rod	Steel chrome plated
	Bodies	Black painted steel, RAL or galvanised
	End fittings	Steel zinc plated

COMPRESSION GAS SPRINGS

RODS / BODIES (mm)	FORCES (N)	STROKE (mm)
2mm / 6mm	5-40	5-50
3mm / 8mm	5-100	10-80
3mm / 10mm	5-100	10-80
4mm / 12mm	10-180	10-200
6mm / 15mm	40-400	20-300
6mm / 19mm	40-400	20-300
8mm / 19mm	50-700	40-500
8mm / 23mm	50-700	40-500
10mm / 23mm	100-1200	40-700
10mm / 28mm	100-1200	40-700
10mm / 40mm	150-1200	30-700
14mm / 28mm	150-2500	50-700
14mm / 40mm	150-2500	50-700
20mm / 40mm	300-5000	50-600
22mm / 40mm	500-6000	50-1000
25mm / 55mm	500-7500	100-1000
30mm / 65mm	750-10000	100-1000

TRACTION GAS SPRINGS

RODS / BODIES (mm)	FORCES (N)	STROKE (mm)
6mm / 19mm	30-350	30-400
10mm / 28mm	150-1200	60-600
10mm / 40mm	200-2000	10-590
28mm / 40mm	500-5000	50-700

The options below are available on special production with threaded ends (lead time of approximately 3-5 weeks):

- Valve into the body thread
- Valve at 90° in the body thread
- Rod wiper ring
- Internal rod seal for locking gas spring
- Grease chamber
- Protection tube (possible on standard gas springs)
- Locking tube (possible on standard gas springs)
- Special construction for high temperatures
- Special construction for low temperatures
- Full 304 stainless steel construction (Wk 1.4305)
- Full 316 stainless steel construction (Wk 1.4571)
- Food oil inside the gas springs

SPECIAL MADE LOCKING GAS SPRINGS

BM© locking gas springs can be locked at any point along their stroke. Regardless of the application (medical beds, stretchers, lifts, etc.), you can lock and unlock the spring as required. Give your imagination free according to the various models offered in the range: Elastic, Rigid, Fully rigid locking components.

By pushing the release pin integrated into the gas spring rod, you will actuate opening of the piston valve enabling the fluid to move: nitrogen in the case of elastic locking and oil in the case of rigid locking components. When you release the pin, the spring will lock in position.

BM© gas springs may be made from steel, 303/304 stainless steel or 316L/316Ti stainless steel.

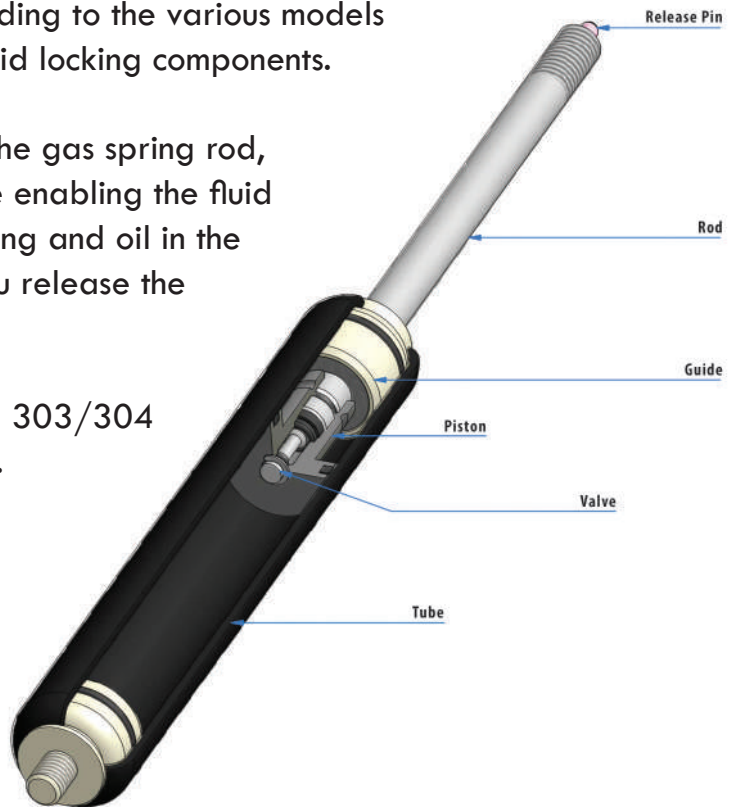

DELIVERY WITHIN 24 TO 48H

REQUEST FOR EQUIVALENCE (SCREWED OR WELDED EYES)

Brand :
Reference :

Threaded end
 Steel
 Stainless Steel

F1 Force : **N**

Stroke =

Length =

Rod end fitting

Eyelet

Length a1 : mm
 ∅ Hole d1 : mm
 Thickness : mm

Ball socket

Length a1 : mm
 ∅ Ball d1 : mm
 Material :
 Steel Plastic

Ball joint

Length a1 : mm
 Length b1 : mm
 Thread m1 : M
 Material :
 Steel Plastic

Fork

Length a1 : mm
 ∅ Hole : mm
 Thickness : mm

Cylinder end fitting

Eyelet

Length a2 : mm
 ∅ Hole d2 : mm
 Thickness : mm

Ball socket

Length a1 : mm
 ∅ Ball d1 : mm
 Material :
 Steel Plastic

Ball joint

Length a1 : mm
 Length b1 : mm
 Thread m1 : M
 Material :
 Steel Plastic

Fork

Length a2 : mm
 ∅ Hole : mm
 Thickness : mm

Welded eyes

F1 Force : **N**

Stroke =

Extended length =

Thickness =

Dimensions should be taken with the rod fully open

REQUEST OF EQUIVALENCE

Application type :

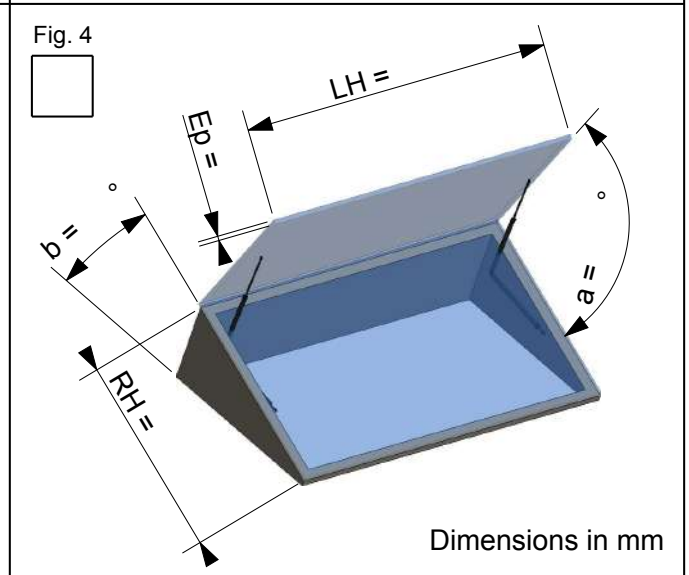
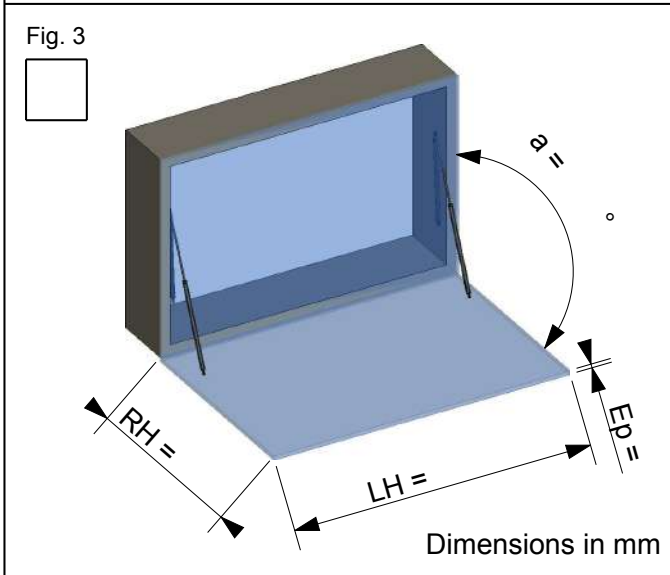
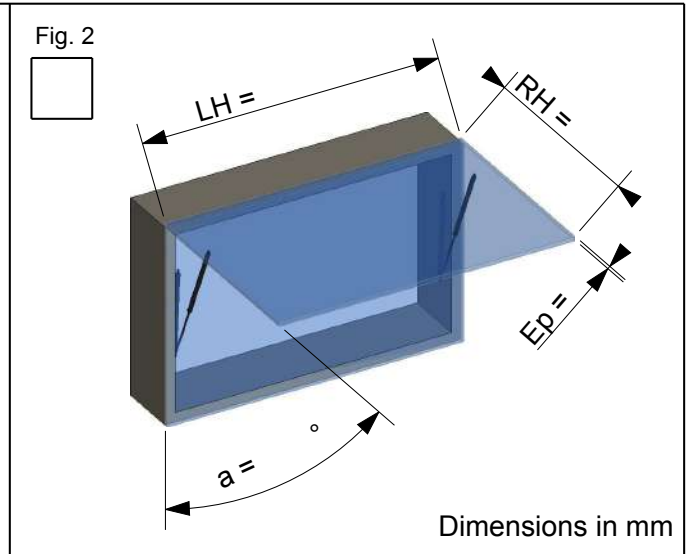
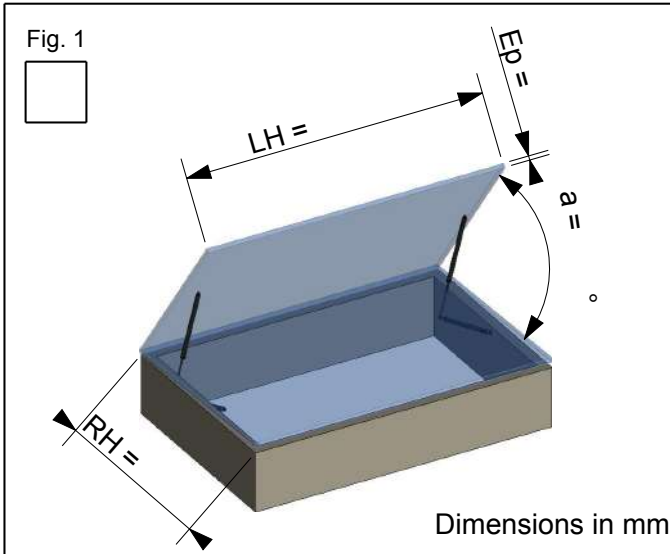

Position of the hinge on the opening part :

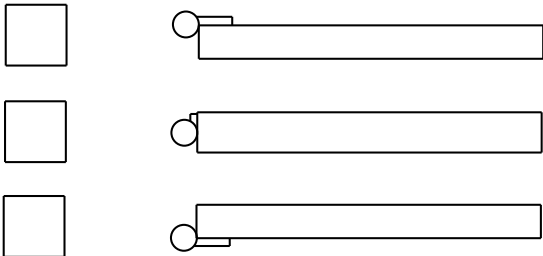

The precision is important to obtain a reliable result

Weight of the opening part : Kg

Other informations (temperature, wet environnement, dusty, stainless steel,...) :

.....

.....

.....

Rod end fitting :

Cylinder end fitting :



Please send back this document to :

info@bertholdmarx.com



MANUFACTURE FRANCAISE
DE RESSORTS A GAZ

General Sales conditions

The warranty relating to our products only covers their exchange and can under no circumstances cover replacement costs or other costs resulting from this replacement. Any claim relating to the conformity of products, to the exclusion of any transportation dispute, must be made by recorded delivery with acknowledgement slip, within five days of the delivery date.

No returned goods shall be accepted unless explicitly authorised in writing by BERTHOLD MARX. In this instance, the goods will be sent at the Purchaser's risk and shipped carriage paid in their original packing, in perfect condition and accompanied by a return document completed by us. Any return accepted will result in a reduction in the trade-in value of the goods of at least 40% of the price excluding VAT and will result in the issue of a credit note.

The diagrams and recommendations are given for information only and cannot be considered as consisting the object of sale. They can therefore, under no circumstances, engage the liability of BERTHOLD MARX. Whatever the circumstances, it is up to the purchaser to have them confirmed by its engineering office, or its customer, or any other qualified professional service provider.

The delivery deadlines stated in the documents from BERTHOLD MARX are for illustrative purposes only and can under no circumstances engage the liability of our company, nor be the subject of penalties for delays.

In the event of a failure to collect or take delivery of goods manufactured or ordered specifically for the purchaser, within a period of eight days, after notification by registered letter with acknowledgement slip, the latter remains liable for the full sale price and associated costs of the goods.

The gas spring is not a safety component by itself and shall be supplemented by a locking system if necessary. (cf. our safety protocol available on our website www.bertholdmarx.com)

Our goods, even sold carriage paid are shipped at the consignee's risk. Special delivery arrangements can be looked into with the customer. We kindly request you to check the weight of the package upon arrival. We accept no liability for missing items or breakages linked to transportation, if reservations have not been made upon reception of the goods from the transport company.

By express agreement, failure to pay for our goods by the deadline, will result in the immediate request for all remaining sums due regardless of the method payment set out in the application, pursuant to the Penalty Clause, of a penalty equal to 15% of the due amounts.

In accordance with Law No. 80335 of 12/05/1980, this sale will only be complete after payment of the full price. For as long as the price shall not be fully paid, the goods sold will remain the property of the seller.

Regulation: The usual payment terms for customers is 30 days net from the date of the invoice, other payment terms may be considered in accordance with the current economic modernisation law in force (LME). A discount of 0.5% is available for payments within ten days. In the case of paying with a discount, the total VAT that can be recovered shall be reduced as a consequence of this

Beyond the deadline stated on the invoice, and in accordance with the law, a late penalty of a rate equal to three times the legal interest rate can be applied. A standard penalty of €40 for recovery costs will be added to the penalties which are already due for delays in payment (Decree No. 2012-1115 of 02/10/2012).

Failure by the purchaser to pay a single fraction of the price at the agreed deadline and 8 days after a formal notice, the sale concerned will be fully cancelled, at the seller's discretion.

This may also result in the appointment of an expert to observe the condition of the returned goods and to set the value; on this basis, the accounts of the parties are liquid, given the damages-interest incurred by the purchaser to complete the sale.

Only French law is applicable. In the event of a dispute, only courts and tribunals in Strasbourg have authority in the event of legal proceedings.



BERTHOLD MARX

**MANUFACTURE FRANCAISE
DE RESSORTS A GAZ**

OUR OTHER CATALOGUES

Silentbloc Accessories (FR)

Rubber Sealing (FR)

Our contact details :

BERTHOLD MARX
1 rue de la gravière
67116 REICHSTETT - FRANCE

Phone : +33 3 88 40 31 61
Mail : info@bertholdmarx.com
Site : www.bertholdmarx.com



DISTRIBUTOR