

REV.	DESCRIPTION	DATE	BY

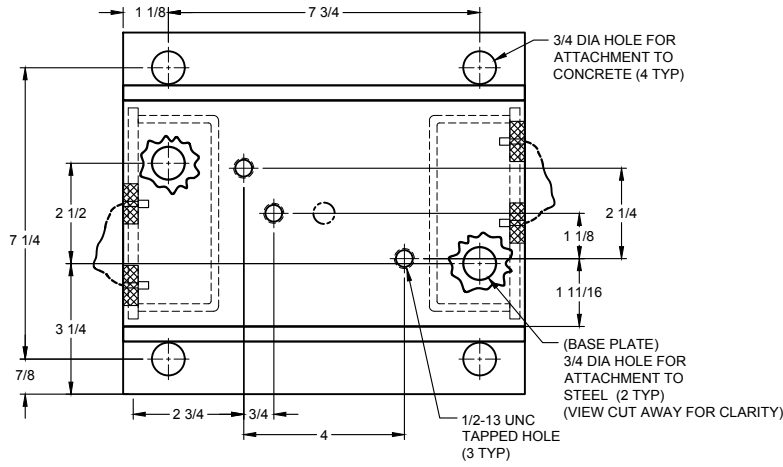

MODEL MS-2E SEISMICALLY RESTRAINED VIBRATION ISOLATOR FOR 2" DEFLECTION				
SEISMIC MOUNT SIZE	RATED LOAD (LBS)	RATED DEFLECTION (IN)	SPRING RATE (LBS/IN)	COLOR CODE
MSH-2E-80	80	2.00	40	BLACK
MSH-2E-150	150	2.00	75	GREEN
MSH-2E-300	300	2.00	150	DK YELLOW
MSH-2E-500	500	2.00	250	BLUE
MSH-2E-1000	1000	2.00	500	TAN
MSH-2E-1400	1400	1.87	750	RED
MSH-2E-1600N	1600	2.13	750	TAN/ RED
MSH-2E-1800	1800	1.71	1050	DK GRAY
MSH-2E-2050	2050	1.64	1250	DK BLUE
MSH-2E-2250N	2250	1.62	1370	DK BLUE/ BLUE
MSH-2E-2460N	2460	1.64	1500	DK BLUE/ RED
MSH-2E-2700N	2700	1.64	1650	DK BLUE/ DK GREEN

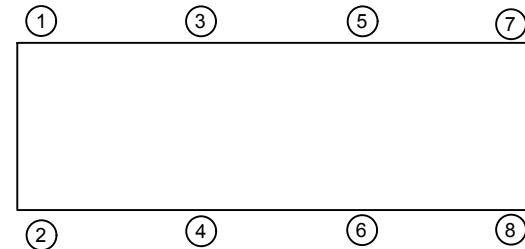
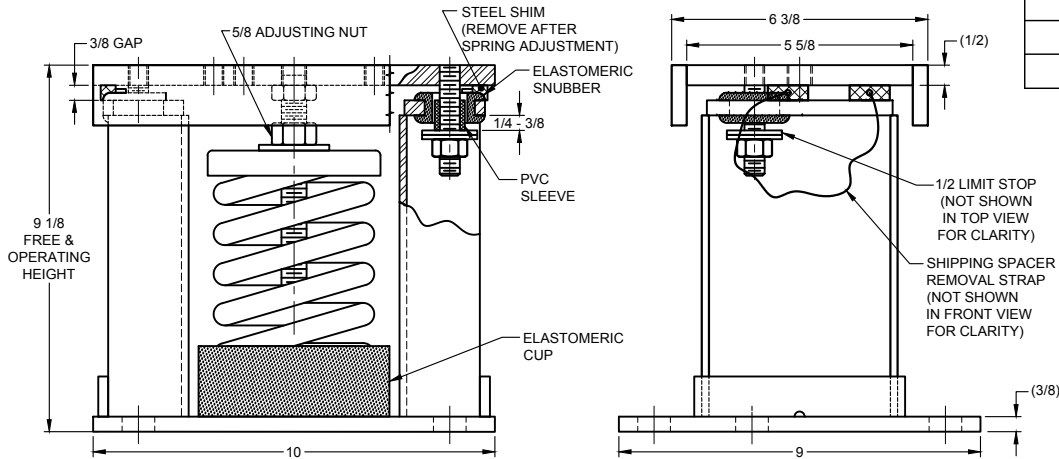

- NOTES:
- ALL DIMENSIONS ARE IN INCHES, INTERPRET PER ANSI Y14.
 - STANDARD FINISH: HOUSING - POWDER COATED OR PAINTED (COLOR:BLACK), SPRING - POWDER COAT (COLOR: SEE TABLE), HARDWARE ZINC-ELECTROPLATE.
 - EQUIPMENT MUST BE BOLTED OR WELDED TO THE TOP PLATE TO MEET ALLOWABLE SEISMIC RATINGS.
 - ISOLATOR BASE PLATE MUST BE ANCHORED TO CONCRETE WITH (4) 11/16 DIA ANCHORS.
 - ALL SPRINGS ARE DESIGNED FOR 50% OVERLOAD CAPACITY.
 - REFER TO SHEET 2 OF 2 FOR INSTALLATION INSTRUCTIONS.
 - RATED DEFLECTIONS ARE WITHIN 25% OF NOMINAL. HIGHER DEFLECTIONS ARE ALLOWED IF THEY MEET SPECIFICATIONS.

ISOLATOR SELECTIONS	
LOC 1:	LOC 2:
LOC 3:	LOC 4:
LOC 5:	LOC 6:
LOC 7:	LOC 8:
CUSTOMER EQP'T. TAG:	

NOTE: MATERIAL SHOWN IS FOR (1) SET.

OTHER MATERIALS, COMPOUNDS, OR FINISHES WITH EQUAL OR SUPERIOR PROPERTIES MAY BE SUBSTITUTED AS THEY BECOME AVAILABLE.

CERTIFIED FOR:

JOB NAME: _____
 CUSTOMER : _____
 CUSTOMER P.O.: _____
 SALES ORDER: _____

MODEL MSH-2E 80-2700 LBS. VIBRATION ISOLATOR WITH INTEGRAL SEISMIC RESTRAINT AND INTERNAL ADJUSTMENT 2 INCH DEFLECTION



THE VMC GROUP
 The Power of Together
 Bloomingdale, NJ 07403
 Houston, TX 77041

SCALE:	NONE	Member VISMA
SHEET:		
DRAWING NO.:		REVISION

REV.	DESCRIPTION	DATE	BY

1. READ INSTRUCTIONS IN THEIR ENTIRETY BEFORE BEGINNING INSTALLATION.

- ISOLATORS ARE SHIPPED FULLY ASSEMBLED AND ARE TO BE POSITIONED IN ACCORDANCE WITH THE SUBMITTAL DRAWINGS OR AS OTHERWISE RECOMMENDED.
- SET ISOLATORS ON FLOOR, HOUSEKEEPING PAD, OR SUB-BASE, ENSURING THAT ALL ISOLATOR CENTERLINES MATCH THE EQUIPMENT MOUNTING HOLES. THE VMC GROUP RECOMMENDS THAT THE ISOLATOR BASE PLATES ("B") BE INSTALLED ON A LEVEL SURFACE. SHIM OR GROUT AS REQUIRED, LEVELING ALL ISOLATOR BASE PLATES AT THE SAME ELEVATION (1/4-INCH MAXIMUM DIFFERENCE CAN BE TOLERATED).
- ANCHOR ALL ISOLATORS TO THE FLOOR, HOUSEKEEPING PAD, OR SUB-BASE USING THRU HOLES ("C") FOR CONCRETE OR ("D") FOR STEEL AS REQUIRED. USE ANCHORS MEETING THE DESIGN REQUIREMENTS SPECIFIED ON SHEET 1 OF 2. WELDING TO STEEL IS PERMITTED PROVIDING THE WELD ACHIEVES THE REQUIRED STRENGTH.
- ISOLATORS ARE SHIPPED TO THE JOBSITE WITH (2) REMOVABLE SPACER SHIMS ("E") BETWEEN THE TOP PLATE AND THE HOUSING. THESE SHIMS **MUST** BE IN PLACE WHEN THE EQUIPMENT IS POSITIONED OVER THE ISOLATORS.
- WITH ALL SHIMS ("E") IN PLACE, PLACE THE MACHINE OR EQUIPMENT ONTO TOP PLATE ("A") OF THE ISOLATORS. BOLT EQUIPMENT SECURELY TO THE ISOLATORS USING MINIMUM ASTM A325 SAE GR. 5) HIGH-STRENGTH BOLTS, MEETING THE REQUIREMENTS (IF ANY) SPECIFIED ON SHEET 1 OF 2. WELDING IS PERMITTED PROVIDING THE WELD ACHIEVES THE REQUIRED STRENGTH.

7. THE ADJUSTMENT PROCESS CAN ONLY BEGIN AFTER THE EQUIPMENT OR MACHINE IS AT ITS FULL OPERATING WEIGHT.

- BACK OFF EACH OF THE (2) OR (4) LIMIT STOP LOCKNUTS ("F") PER ISOLATOR 1/4- TO 3/8-INCH.
- ADJUST EACH ISOLATOR IN SEQUENCE BY TURNING ADJUSTING NUT(S) "G" ONE FULL CLOCKWISE TURN AT A TIME. REPEAT THIS PROCEDURE ON ALL ISOLATORS, ONE AT A TIME. CHECK THE LIMIT STOP LOCKNUTS ("F") PERIODICALLY TO ENSURE THAT CLEARANCE BETWEEN THE WASHER AND RUBBER GROMMET IS MAINTAINED. STOP ADJUSTMENT OF AN ISOLATOR ONLY WHEN THE TOP PLATE ("A") HAS RISEN JUST ABOVE THE SHIM ("E").
- REMOVE ALL SPACER SHIMS ("E").
- FINE ADJUST ISOLATORS TO LEVEL EQUIPMENT.
- ADJUST ALL LIMIT STOP LOCKNUTS ("F") PER ISOLATOR TO OBTAIN 3/8-INCH GAP. THE LIMIT STOP NUTS MUST BE KEPT AT THIS 3/8-INCH GAP TO ENSURE UNIFORM BOLT LOADING DURING UPLIFT (AS IN THE CASE WHEN A COOLING TOWER IS DRAINED).
- INSTALLATION IS COMPLETE.

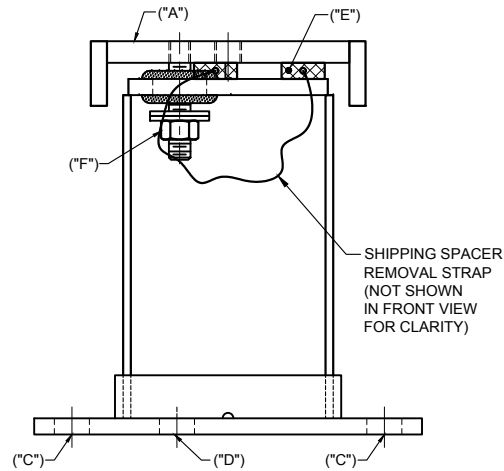
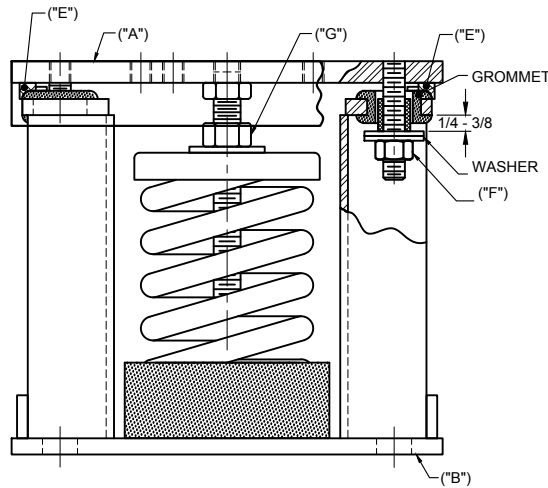

OTHER MATERIALS, COMPOUNDS, OR FINISHES WITH EQUAL OR SUPERIOR PROPERTIES MAY BE SUBSTITUTED AS THEY BECOME AVAILABLE.

CERTIFIED FOR:

JOB NAME: _____
 CUSTOMER : _____
 CUSTOMER P.O.: _____
 SALES ORDER: _____

MODEL MSH-2E 80-2700 LBS. VIBRATION ISOLATOR WITH INTEGRAL SEISMIC RESTRAINT AND INTERNAL ADJUSTMENT 2 INCH DEFLECTION



THE VMC GROUP
 The Power of Together
 Bloomingdale, NJ 07403
 Houston, TX 77041

SCALE :

NONE

SHEET:



DRAWING NO.:

REVISION