

REV.	DESCRIPTION	DATE	BY

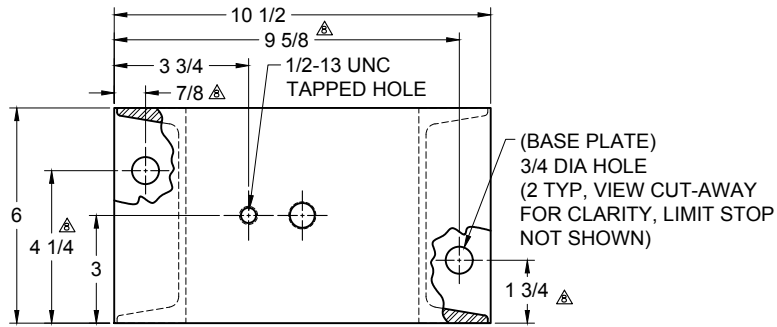

TYPE MH-3D SPRING ISOLATORS WITH INTERNAL ADJUSTMENT				
MODEL	MAX LOAD (LBS)	DEFLECTION (IN)	SPRING RATE (LB/IN)	SPRING COLOR CODE
MH-3D-800	800	3.00	267	DK GRAY
MH-3D-1225	1225	2.94	417	RED
MH-3D-1510	1510	2.52	600	MED GRAY
MH-3D-2035	2035	2.54	800	DK YELLOW

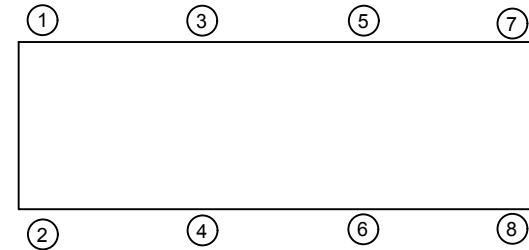
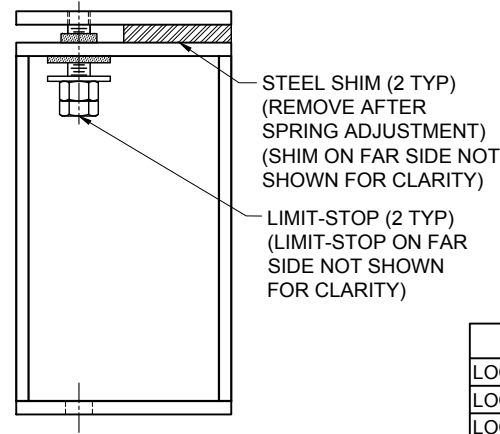
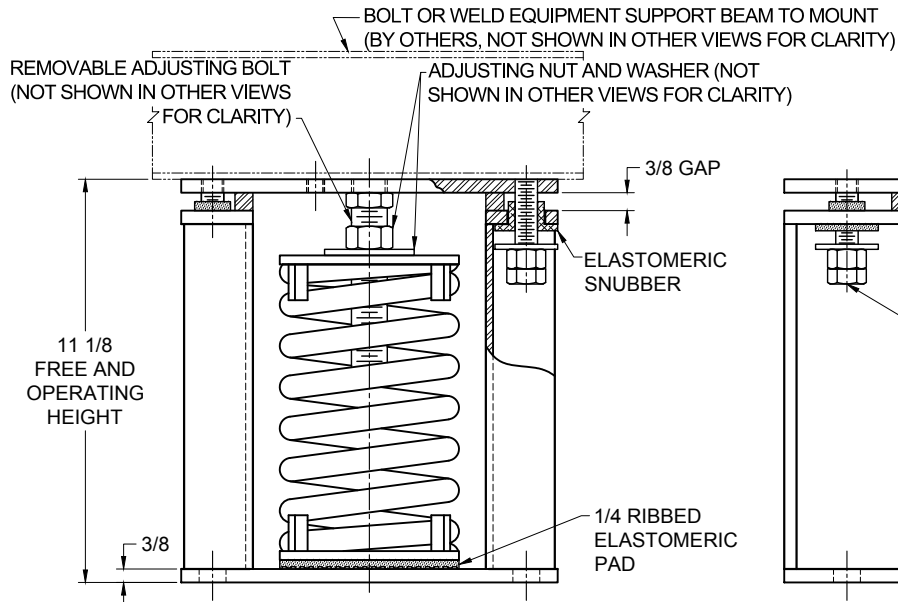

ISOLATOR SELECTIONS	
LOC 1:	LOC 2:
LOC 3:	LOC 4:
LOC 5:	LOC 6:
LOC 7:	LOC 8:
CUSTOMER EQPT. TAG:	

NOTE: MATERIAL SHOWN IS FOR (1) SET.

NOTES:

1. ALL DIMENSIONS ARE IN INCHES, INTERPRET PER ANSI Y14.
2. UNLESS OTHERWISE NOTED, DIMENSIONS FOR STYLE APPLY TO ALL OTHER STYLES.
3. FINISH: HOUSINGS- POWDER COAT, SPRINGS- POWDER COAT, HARDWARE- ZINC ELECTROPLATE.
4. REFER TO SHEET 2 OF 2 FOR INSTALLATION INSTRUCTIONS.
5. INNER SPRING (WHEN USED) NOT SHOWN.
6. ALL SPRINGS ARE DESIGNED WITH 50% OVER TRAVEL.
7. SPRING PACKAGE MAY BE REMOVED WITH SHIMS IN PLACE. CONTACT A FACTORY REPRESENTATIVE FOR SPRING REMOVAL INSTRUCTIONS.
8. DIMENSIONS APPLY TO BOTH TOP BOLT DOWN AND BASE PLATE ANCHORING HOLE.
9. RATED DEFLECTIONS ARE WITHIN 25% OF NOMINAL. HIGHER DEFLECTIONS ARE ALLOWED IF THEY MEET SPECIFICATIONS.

OTHER MATERIALS, COMPOUNDS, OR FINISHES WITH EQUAL OR SUPERIOR PROPERTIES MAY BE SUBSTITUTED AS THEY BECOME AVAILABLE.

CERTIFIED FOR:

JOB NAME: _____
 CUSTOMER : _____
 CUSTOMER P.O.: _____
 SALES ORDER: _____

MODEL MH-3D 800-2035 LBS.
 SPRING ISOLATORS WITH
 INTERNAL ADJUSTMENT
 3 INCH DEFLECTION



THE VMC GROUP
The Power of Together
 Bloomingdale, NJ 07403
 Houston, TX 77041

SCALE:	NONE	
SHEET:		
DRAWING NO.:		REVISION

REV.	DESCRIPTION	DATE	BY

READ INSTRUCTIONS IN THEIR ENTIRETY BEFORE BEGINNING.

1. LOCATE ISOLATORS UNDER EQUIPMENT AFTER DETERMINING POSITIONS DESIGNATED IN THE THE VMC GROUP SUBMITTAL, SHEET 1.
2. ALL LIMIT BOLTS ARE FACTORY SET AND BONDED IN PLACE. THE SHIPPING NUT ON THE LIMIT BOLT MUST BE LOWERED UNTIL IT TOUCHES THE BOLT HEAD. THE NUT WAS SHIPPED IN THE RAISED POSITION. DO NOT ATTEMPT TO READJUST THE LIMIT BOLTS. FACTORY SETTING ASSURES UNIFORM BOLT LOADING IF UPLIFT OCCURS, AS IN THE CASE OF A COOLING TOWER BEING DRAINED.
3. THE VMC GROUP RECOMMENDS BOLTING ALL ISOLATORS TO A FLAT SURFACE. WHEN A WEIGHT CHANGE OCCURS IN EXCESS OF 20% OF EQUIPMENT OPERATING WEIGHT, THE ISOLATOR BASE PLATE **MUST** BE BOLTED. THE LOAD MUST BE CENTERED ON THE ISOLATOR TO AVOID ECCENTRIC LOADING OF TOP PLATE, WHICH WOULD TILT THE TOP PLATE OF THE ISOLATOR. THE TOP PLATE OF THE ISOLATOR MUST BE UNIFORMLY LOADED ACROSS ENTIRE LENGTH OF TOP PLATE OR THE EQUIPMENT MUST BE BLOCKED UNTIL LOAD IS TRANSFERRED TO THE ISOLATOR. THE VMC GROUP MUST BE ADVISED BEFORE THE ISOLATORS ARE RELEASED FOR PRODUCTION TO EVALUATE ANY VARIANCE TO THESE REQUIREMENTS.
4. WHEN THE APPLICATION IS OUTDOORS AND THE EQUIPMENT WILL BE SUBJECT TO HIGH WINDS, THE OWNER'S REPRESENTATIVE MUST EVALUATE ANCHOR TYPE AND SIZE TO EFFECTIVELY RESIST WIND FORCES. **TYPE MH ISOLATORS ARE NOT SUITABLE FOR SEISMIC APPLICATIONS. USE VMC GROUP TYPES MS ISOLATORS TO ISOLATE EQUIPMENT THAT WILL BE SUBJECT TO SEISMIC FORCES.**
5. ISOLATORS ARE SHIPPED TO THE JOB SITE WITH SHIMS BETWEEN THE TOP PLATE AND HOUSING. THESE SHIMS **MUST** BE IN PLACE WHEN ISOLATOR IS POSITIONED UNDER EQUIPMENT.
6. THE ADJUSTMENT PROCESS CAN ONLY BEGIN AFTER FULL OPERATING WEIGHT IS REACHED. THE ADJUSTMENTS CAN BE MADE BY STARTING AT ANY ISOLATOR AND TURNING THE ADJUSTING NUT CLOCKWISE TWO TURNS. PROCEED AROUND THE EQUIPMENT TO EACH ISOLATOR ADJUSTING EACH TWO TURNS TO COMPRESS THE SPRINGS UNIFORMLY. CONTINUE THIS ADJUSTING PROCESS UNTIL ONE ISOLATOR JUST RISES OFF THE SHIMS. STOP ADJUSTMENT ON THAT AND OTHER ISOLATORS AS THEY RISE OFF SHIMS APPROXIMATELY 1/32". WHEN ALL ISOLATORS HAVE RISEN ABOVE THE SHIMS, THE ADJUSTMENT PROCESS IS COMPLETE. REMOVE ALL SHIMS.
7. FURTHER ATTENTION TO THE INSTALLATION IS NOT NORMALLY REQUIRED. THE VMC GROUP SUGGESTS A SEMIANNUAL INSPECTION OF THE COMPONENTS FOR POSSIBLE CORROSION PROBLEMS. IF PROBLEMS ARE OBSERVED, CONSULT THE VMC GROUP OR CORROSION CONTROL EXPERTS TO RECTIFY THE PROBLEM.
8. IF THE SPRING PACKAGE MUST BE REMOVED, CONTACT FACTORY REPRESENTATIVE FOR DETAILED PROCEDURE.

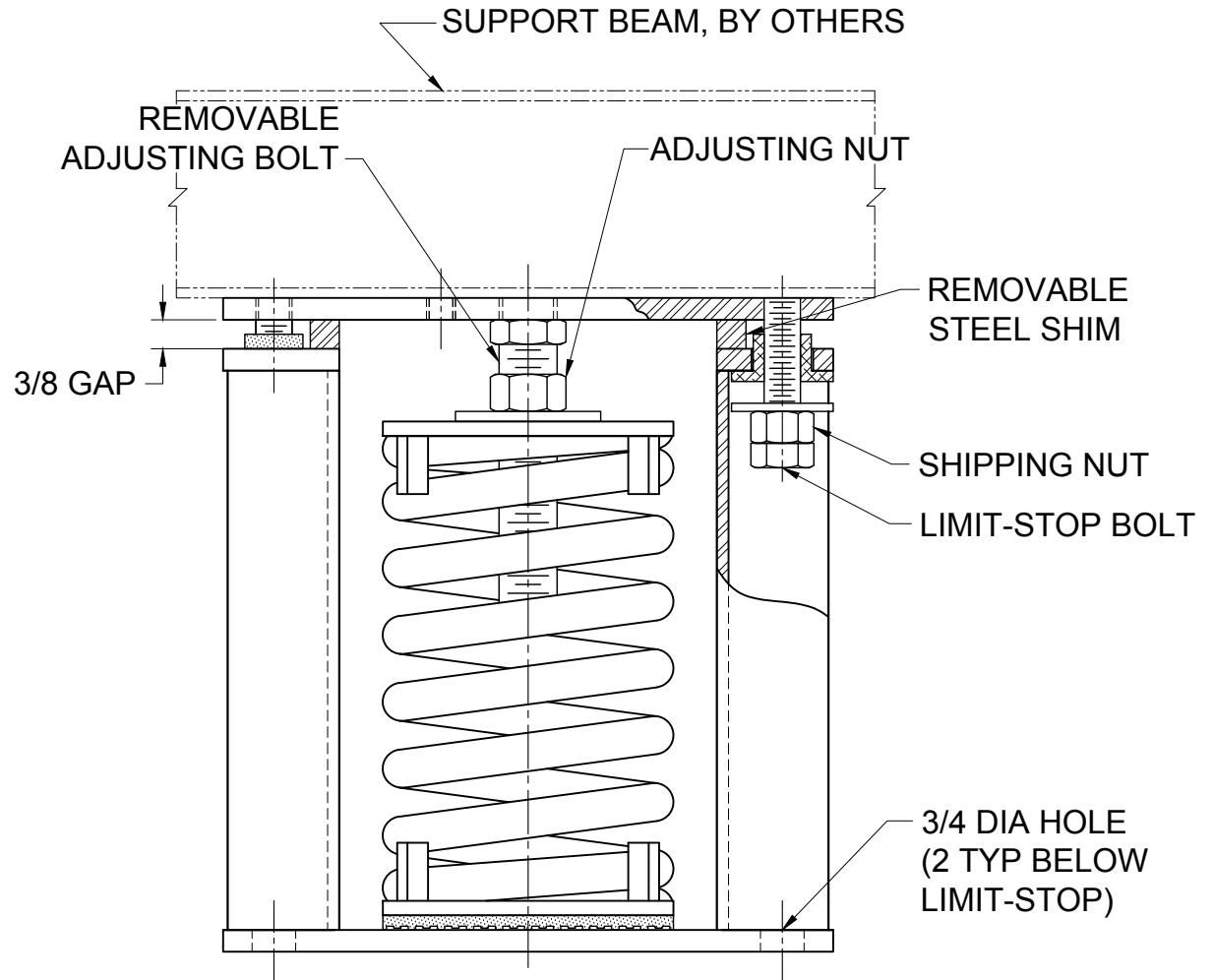

OTHER MATERIALS, COMPOUNDS, OR FINISHES WITH EQUAL OR SUPERIOR PROPERTIES MAY BE SUBSTITUTED AS THEY BECOME AVAILABLE.

CERTIFIED FOR:

JOB NAME: _____
 CUSTOMER : _____
 CUSTOMER P.O.: _____
 SALES ORDER: _____

**MODEL MH-3D 800-2035 LBS.
 SPRING ISOLATORS WITH
 INTERNAL ADJUSTMENT
 3 INCH DEFLECTION**



THE VMC GROUP
 The Power of Together
 Bloomingdale, NJ 07403
 Houston, TX 77041

SCALE:	NONE	
SHEET:		
DRAWING NO.:		REVISION