

| REV. | DESCRIPTION | DATE | BY |
|------|-------------|------|----|
|      |             |      |    |

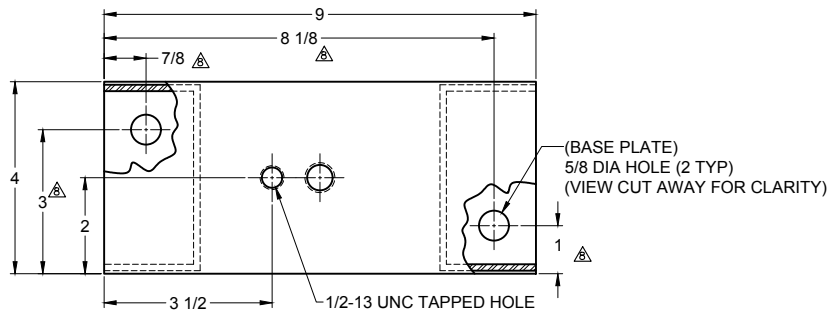

| TYPE MH-1E SPRING ISOLATORS WITH INTERNAL ADJUSTMENT |                |                 |                     |                   |
|--|----------------|-----------------|---------------------|-------------------|
| MODEL  | MAX LOAD (LBS) | DEFLECTION (IN) | SPRING RATE (LB/IN) | SPRING COLOR CODE |
| MH-1E-195  | 195            | 1.95            | 100                 | DK BLUE           |
| MH-1E-400  | 400            | 1.32            | 303                 | BLACK             |
| MH-1E-530N <sup>1</sup>                              | 530            | 1.17            | 453                 | BLACK/ DK BLUE    |
| MH-1E-650  | 650            | 1.05            | 619                 | RED               |
| MH-1E-825N <sup>1</sup>                              | 825            | 1.07            | 771                 | RED/ DK BLUE      |
| MH-1E-1000   | 1000           | 1.00            | 1000                | TAN               |
| MH-1E-1200N <sup>1</sup>                             | 1200           | 1.04            | 1154                | TAN/ DK BLUE      |
| MH-1E-1400   | 1400           | 1.00            | 1400                | PINK              |
| MH-1E-1700N <sup>1</sup>                             | 1700           | 1.10            | 1545                | PINK/ DK BLUE     |
| MH-1E-2000   | 2000           | 1.11            | 1800                | WHITE             |
| MH-1E-2330N <sup>1</sup>                             | 2330           | 1.11            | 2100                | WHITE/RED         |
| MH-1E-2575N <sup>1</sup>                             | 2575           | 1.11            | 2313                | WHITE/DK PURPLE   |
| MH-1E-2990N <sup>1</sup>                             | 2990           | 1.12            | 2681                | WHITE/DK GREEN    |
| MH-1E-3250N <sup>1</sup>                             | 3250           | 1.04            | 3125                | WHITE/GRAY        |

**NOTES:**

1. TWO NESTED SPRINGS YIELD THIS LOAD. THE COLOR CODE IS FOR OUTER SPRING/ INNER SPRING.

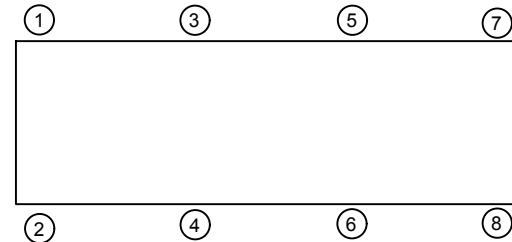
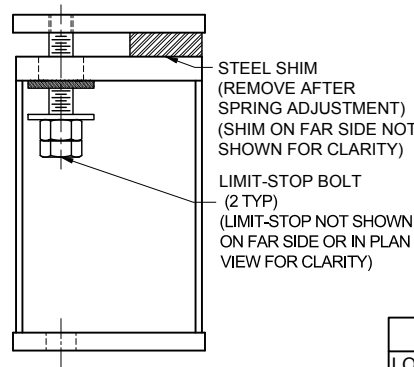
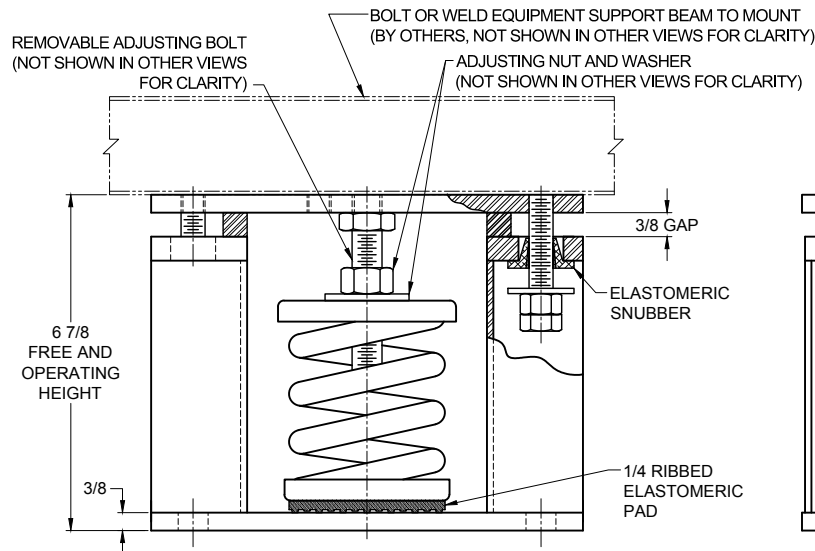

**NOTES:**

- ALL DIMENSIONS ARE IN INCHES, INTERPRET PER ANSI Y14.
- UNLESS OTHERWISE NOTED, DIMENSIONS FOR STYLE APPLY TO ALL OTHER STYLES.
- FINISH: HOUSINGS- POWDER COAT, SPRINGS- POWDER COAT, HARDWARE- ZINC ELECTROPLATE.
- REFER TO SHEET 2 OF 2 FOR INSTALLATION INSTRUCTIONS.
- INNER SPRING (WHEN USED) NOT SHOWN.
- ALL SPRINGS ARE DESIGNED WITH 50% OVER TRAVEL.
- SPRING PACKAGE MAY BE REMOVED WITH SHIMS IN PLACE. CONTACT A FACTORY REPRESENTATIVE FOR SPRING REMOVAL INSTRUCTIONS.
- DIMENSIONS APPLY TO BOTH TOP BOLT DOWN AND BASE PLATE ANCHORING HOLE.
- RATED DEFLECTIONS ARE WITHIN 25% OF NOMINAL. HIGHER DEFLECTIONS ARE ALLOWED IF THEY MEET SPECIFICATIONS.

**ISOLATOR SELECTIONS**

|                     |        |
|---------------------|--------|
| LOC 1:              | LOC 2: |
| LOC 3:              | LOC 4: |
| LOC 5:              | LOC 6: |
| LOC 7:              | LOC 8: |
| CUSTOMER EQPT. TAG: |        |

NOTE: MATERIAL SHOWN IS FOR (1) SET.

OTHER MATERIALS, COMPOUNDS, OR FINISHES WITH EQUAL OR SUPERIOR PROPERTIES MAY BE SUBSTITUTED AS THEY BECOME AVAILABLE.

**CERTIFIED FOR:**

JOB NAME: \_\_\_\_\_  
 CUSTOMER : \_\_\_\_\_  
 CUSTOMER P.O.: \_\_\_\_\_  
 SALES ORDER: \_\_\_\_\_

**MODEL MH-1E 195-3250 LBS. SPRING ISOLATORS WITH INTERNAL ADJUSTMENT 1 INCH DEFLECTION**



**THE VMC GROUP**  
*The Power of Together*  
 Bloomingdale, NJ 07403  
 Houston, TX 77041

SCALE :

NONE

SHEET:



DRAWING NO.:

REVISION

| REV. | DESCRIPTION | DATE | BY |
|------|-------------|------|----|
|      |             |      |    |

**READ INSTRUCTIONS IN THEIR ENTIRETY BEFORE BEGINNING.**

1. LOCATE ISOLATORS UNDER EQUIPMENT AFTER DETERMINING POSITIONS DESIGNATED IN THE VMC GROUP SUBMITTAL, SHEET 1.
2. ALL LIMIT BOLTS ARE FACTORY SET AND BONDED IN PLACE. THE SHIPPING NUT ON THE LIMIT BOLT MUST BE LOWERED UNTIL IT TOUCHES THE BOLT HEAD. THE NUT WAS SHIPPED IN THE RAISED POSITION. DO NOT ATTEMPT TO READJUST THE LIMIT BOLTS. FACTORY SETTING ASSURES UNIFORM BOLT LOADING IF UPLIFT OCCURS, AS IN THE CASE OF A COOLING TOWER BEING DRAINED.
3. THE VMC GROUP RECOMMENDS BOLTING ALL ISOLATORS TO A FLAT SURFACE. WHEN A WEIGHT CHANGE OCCURS IN EXCESS OF 20% OF EQUIPMENT OPERATING WEIGHT, THE ISOLATOR BASE PLATE **MUST** BE BOLTED. THE LOAD MUST BE CENTERED ON THE ISOLATOR TO AVOID ECCENTRIC LOADING OF TOP PLATE, WHICH WOULD TILT THE TOP PLATE OF THE ISOLATOR. THE TOP PLATE OF THE ISOLATOR MUST BE UNIFORMLY LOADED ACROSS ENTIRE LENGTH OF TOP PLATE OR THE EQUIPMENT MUST BE BLOCKED UNTIL LOAD IS TRANSFERRED TO THE ISOLATOR. THE VMC GROUP MUST BE ADVISED BEFORE THE ISOLATORS ARE RELEASED FOR PRODUCTION TO EVALUATE ANY VARIANCE TO THESE REQUIREMENTS.
4. WHEN THE APPLICATION IS OUTDOORS AND THE EQUIPMENT WILL BE SUBJECT TO HIGH WINDS, THE OWNER'S REPRESENTATIVE MUST EVALUATE ANCHOR TYPE AND SIZE TO EFFECTIVELY RESIST WIND FORCES. **TYPE MH ISOLATORS ARE NOT SUITABLE FOR SEISMIC APPLICATIONS. USE VMC GROUP TYPES MS ISOLATORS TO ISOLATE EQUIPMENT THAT WILL BE SUBJECT TO SEISMIC FORCES.**
5. ISOLATORS ARE SHIPPED TO THE JOB SITE WITH SHIMS BETWEEN THE TOP PLATE AND HOUSING. THESE SHIMS **MUST** BE IN PLACE WHEN ISOLATOR IS POSITIONED UNDER EQUIPMENT.
6. THE ADJUSTMENT PROCESS CAN ONLY BEGIN AFTER FULL OPERATING WEIGHT IS REACHED. THE ADJUSTMENTS CAN BE MADE BY STARTING AT ANY ISOLATOR AND TURNING THE ADJUSTING NUT CLOCKWISE TWO TURNS. PROCEED AROUND THE EQUIPMENT TO EACH ISOLATOR ADJUSTING EACH TWO TURNS TO COMPRESS THE SPRINGS UNIFORMLY. CONTINUE THIS ADJUSTING PROCESS UNTIL ONE ISOLATOR JUST RISES OFF THE SHIMS. STOP ADJUSTMENT ON THAT AND OTHER ISOLATORS AS THEY RISE OFF SHIMS APPROXIMATELY 1/32". WHEN ALL ISOLATORS HAVE RISEN ABOVE THE SHIMS, THE ADJUSTMENT PROCESS IS COMPLETE. REMOVE ALL SHIMS.
7. FURTHER ATTENTION TO THE INSTALLATION IS NOT NORMALLY REQUIRED. THE VMC GROUP SUGGESTS A SEMIANNUAL INSPECTION OF THE COMPONENTS FOR POSSIBLE CORROSION PROBLEMS. IF PROBLEMS ARE OBSERVED, CONSULT THE VMC GROUP OR CORROSION CONTROL EXPERTS TO RECTIFY THE PROBLEM.
8. IF THE SPRING PACKAGE MUST BE REMOVED, CONTACT A FACTORY REPRESENTATIVE FOR DETAILED PROCEDURE.

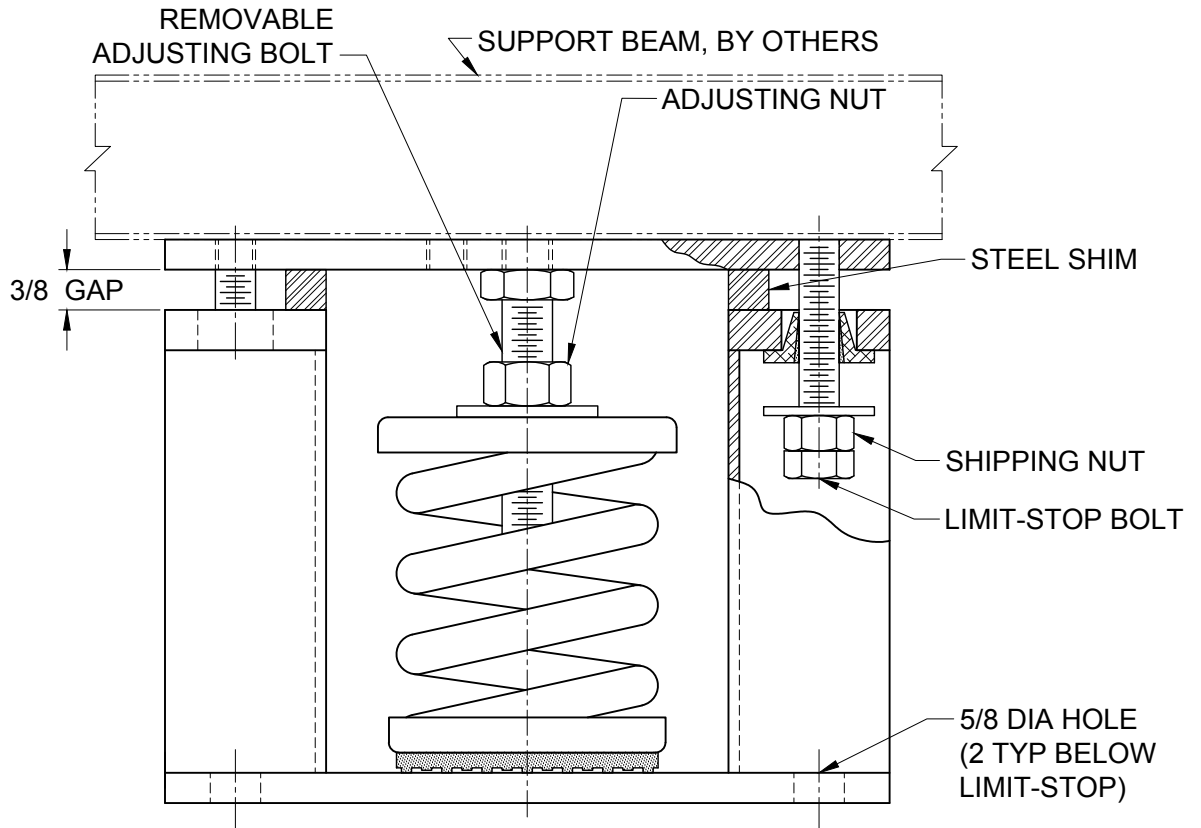

OTHER MATERIALS, COMPOUNDS, OR FINISHES WITH EQUAL OR SUPERIOR PROPERTIES MAY BE SUBSTITUTED AS THEY BECOME AVAILABLE.

**CERTIFIED FOR:**

JOB NAME: \_\_\_\_\_  
 CUSTOMER : \_\_\_\_\_  
 CUSTOMER P.O.: \_\_\_\_\_  
 SALES ORDER: \_\_\_\_\_

**MODEL MH-1E 195-3250 LBS. SPRING  
 ISOLATORS WITH INTERNAL ADJUSTMENT  
 1 INCH DEFLECTION**



**THE VMC GROUP**  
*The Power of Together*  
 Bloomingdale, NJ 07403  
 Houston, TX 77041

SCALE :

NONE

SHEET:



DRAWING NO.:

REVISION