

REV.	DESCRIPTION	DATE	BY

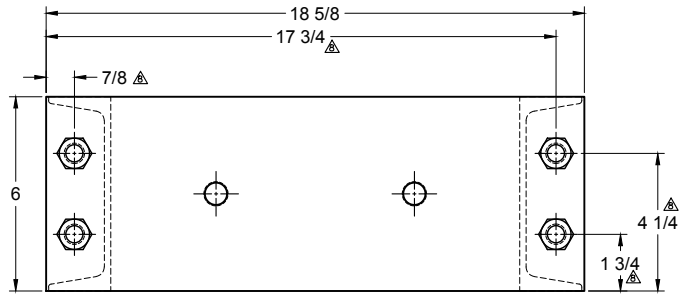

TYPE M2E-3R SPRING ISOLATORS WITH INTERNAL ADJUSTMENT				
MODEL	MAX LOAD (LBS)	DEFLECTION (IN)	SPRING RATE (LB/IN)	SPRING COLOR CODE
M2E-3R-5O <sup>1,2</sup>	11030	2.46	4484	BLACK
M2E-3R-5N <sup>1,2</sup>	16640	2.46	6764	BLACK/BLACK

**NOTES:**

1. TWO NESTED SPRINGS YIELD THIS LOAD. THE COLOR CODE IS FOR OUTER SPRING/ INNER SPRING
2. THIS SPRING OR COMBINATION CAN BE USED FOR 1", 2" & 3" DEFLECTION.

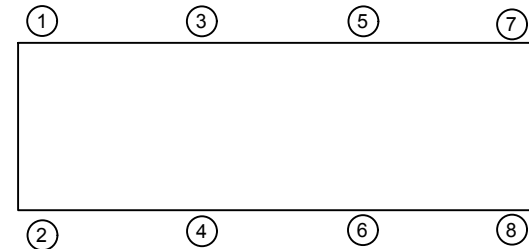
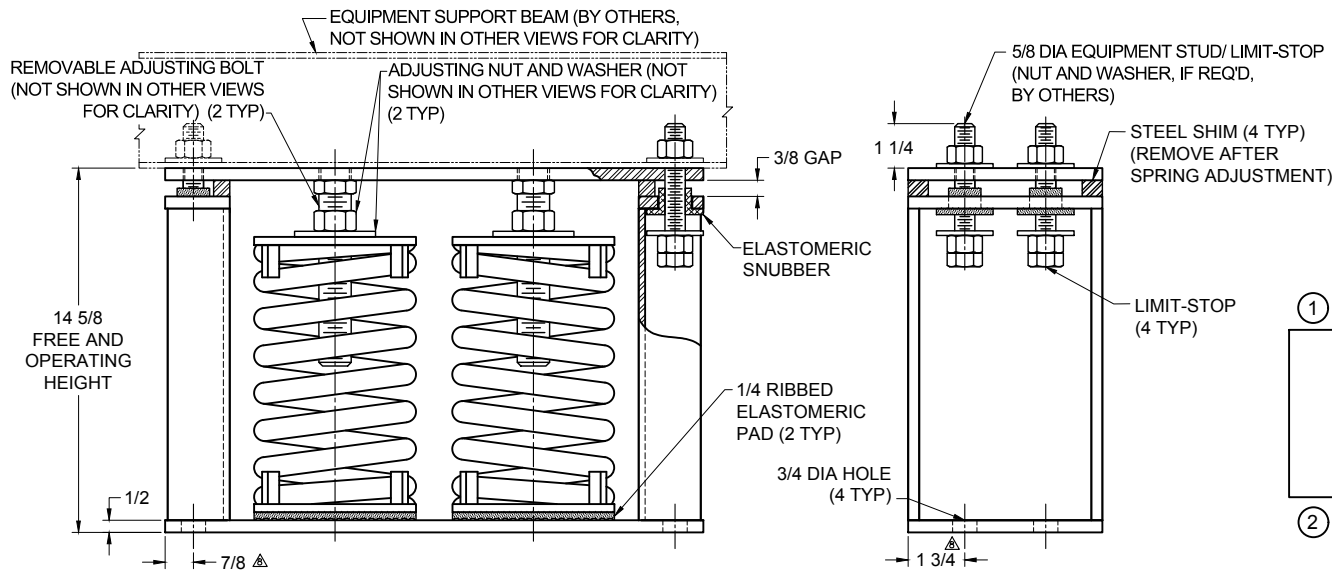

**NOTES:**

1. ALL DIMENSIONS ARE IN INCHES, INTERPRET PER ANSI Y14.
2. UNLESS OTHERWISE NOTED, DIMENSIONS FOR STYLE APPLY TO ALL OTHER STYLES.
3. FINISH: HOUSINGS- POWDER COAT, SPRINGS- POWDER COAT, HARDWARE- ZINC ELECTROPLATE.
4. REFER TO SHEET 2 OF 2 FOR INSTALLATION INSTRUCTIONS.
5. INNER SPRING (WHEN USED) NOT SHOWN.
6. ALL SPRINGS ARE DESIGNED WITH 50% OVER TRAVEL.
7. SPRING PACKAGE MAY BE REMOVED WITH SHIMS IN PLACE. CONTACT A FACTORY REPRESENTATIVE FOR SPRING REMOVAL INSTRUCTIONS.
8. DIMENSIONS APPLY TO BOTH TOP BOLT DOWN AND BASE PLATE ANCHORING HOLE.
9. RATED DEFLECTIONS ARE WITHIN 25% OF NOMINAL. HIGHER DEFLECTIONS ARE ALLOWED IF THEY MEET SPECIFICATIONS.

**ISOLATOR SELECTIONS**

LOC 1:	LOC 2:
LOC 3:	LOC 4:
LOC 5:	LOC 6:
LOC 7:	LOC 8:
CUSTOMER EQP'T. TAG:	

NOTE: MATERIAL SHOWN IS FOR (1) SET.

OTHER MATERIALS, COMPOUNDS, OR FINISHES WITH EQUAL OR SUPERIOR PROPERTIES MAY BE SUBSTITUTED AS THEY BECOME AVAILABLE.

**CERTIFIED FOR:**

JOB NAME: \_\_\_\_\_  
 CUSTOMER : \_\_\_\_\_  
 CUSTOMER P.O.: \_\_\_\_\_  
 SALES ORDER: \_\_\_\_\_

**MODEL M2E-3R 11030-16640 LBS.  
 SPRING ISOLATORS WITH  
 INTERNAL ADJUSTMENT  
 3 INCH DEFLECTION**



**THE VMC GROUP**  
 The Power of Together  
 Bloomingdale, NJ 07403  
 Houston, TX 77041

SCALE :

NONE

SHEET:



DRAWING NO.:

REVISION

REV.	DESCRIPTION	DATE	BY

**READ INSTRUCTIONS IN THEIR ENTIRETY BEFORE BEGINNING.**

1. LOCATE MOUNTS UNDER EQUIPMENT AFTER DETERMINING POSITIONS DESIGNATED IN THE VMC GROUP SUBMITTAL, SHEET 1.
2. ALL LIMIT BOLTS ARE FACTORY SET AND BONDED IN PLACE. THE SHIPPING NUT ON THE LIMIT BOLT MUST BE LOWERED UNTIL IT TOUCHES THE BOLT HEAD. THE NUT WAS SHIPPED IN THE RAISED POSITION. DO NOT ATTEMPT TO RE-ADJUST THE LIMIT BOLTS. FACTORY SETTING ASSURES UNIFORM BOLT LOADING IF UPLIFT OCCURS, AS IN THE CASE OF A COOLING TOWER BEING DRAINED.
3. THE VMC GROUP RECOMMENDS BOLTING ALL MOUNTS TO A FLAT SURFACE. WHEN A WEIGHT CHANGE OCCURS IN EXCESS OF 20% OF EQUIPMENT OPERATING WEIGHT, THE MOUNT BASE PLATE **MUST** BE BOLTED. STYLE "A" TOP PLATE MUST BE USED WITH A WIDE FLANGE BEAM BOLTED TO TOP PLATE AS SHOWN ON SUBMITTAL DRAWING.
4. WHEN THE APPLICATION IS OUTDOORS AND THE EQUIPMENT WILL BE SUBJECT TO HIGH WINDS, THE OWNER'S REPRESENTATIVE MUST EVALUATE ANCHOR TYPE AND SIZE TO EFFECTIVELY RESIST WIND FORCES. **TYPE M2E MOUNTS ARE NOT SUITABLE FOR SEISMIC APPLICATIONS. USE VMC GROUP TYPE MS MOUNTS TO ISOLATE EQUIPMENT THAT WILL BE SUBJECT TO SEISMIC FORCES.**
5. MOUNTS ARE SHIPPED TO THE JOB SITE WITH SHIMS BETWEEN THE TOP PLATE AND HOUSING. THESE SHIMS **MUST** BE IN PLACE WHEN MOUNT IS POSITIONED UNDER EQUIPMENT.
6. THE ADJUSTMENT PROCESS CAN ONLY BEGIN AFTER FULL OPERATING WEIGHT IS REACHED. THE ADJUSTMENTS CAN BE MADE BY STARTING AT ANY MOUNT AND TURNING THE ADJUSTING NUT CLOCKWISE TWO TURNS. PROCEED AROUND THE EQUIPMENT TO EACH ISOLATOR, ADJUSTING EACH TWO TURNS TO COMPRESS THE SPRINGS UNIFORMLY. CONTINUE THIS ADJUSTING PROCESS UNTIL ONE MOUNT JUST RISES OFF THE SHIMS. STOP ADJUSTMENT ON THAT AND OTHER MOUNTS AS THEY RISE OFF SHIMS APPROXIMATELY 1/32". WHEN ALL MOUNTS HAVE RISEN ABOVE THE SHIMS, THE ADJUSTMENT PROCESS IS COMPLETE. REMOVE ALL SHIMS.
7. FURTHER ATTENTION TO THE INSTALLATION IS NOT NORMALLY REQUIRED. THE VMC GROUP SUGGESTS A SEMI-ANNUAL INSPECTION OF THE COMPONENTS FOR POSSIBLE CORROSION PROBLEMS. IF PROBLEMS ARE OBSERVED, CONSULT THE VMC GROUP OR CORROSION CONTROL EXPERTS TO RECTIFY THE PROBLEM.
8. IF THE SPRING PACKAGE MUST BE REMOVED, CONTACT A FACTORY REPRESENTATIVE FOR SPRING REMOVAL INSTRUCTIONS.

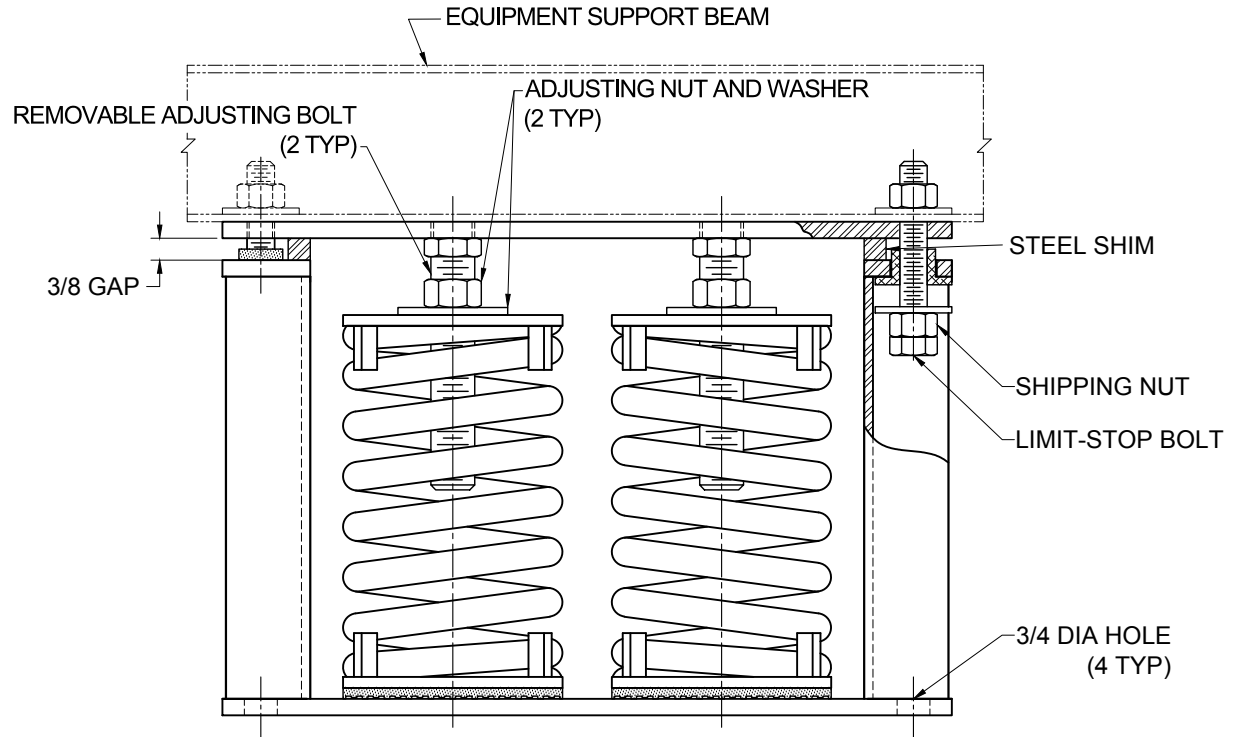

OTHER MATERIALS, COMPOUNDS, OR FINISHES WITH EQUAL OR SUPERIOR PROPERTIES MAY BE SUBSTITUTED AS THEY BECOME AVAILABLE.

**CERTIFIED FOR:**

JOB NAME: \_\_\_\_\_  
 CUSTOMER : \_\_\_\_\_  
 CUSTOMER P.O.: \_\_\_\_\_  
 SALES ORDER: \_\_\_\_\_

**MODEL M2E-3R 11030-16640 LBS.  
 SPRING ISOLATORS WITH  
 INTERNAL ADJUSTMENT  
 3 INCH DEFLECTION**



**THE VMC GROUP**  
*The Power of Together*  
 Bloomingdale, NJ 07403  
 Houston, TX 77041

SCALE:	NONE	
SHEET:		
DRAWING NO.:		REVISION