

120R-101683 REV.: 3

REV.	DESCRIPTION	DATE	BY

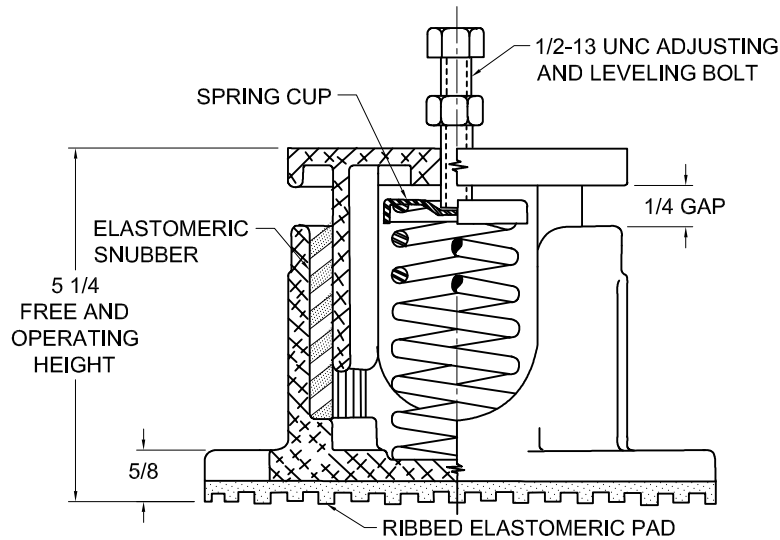
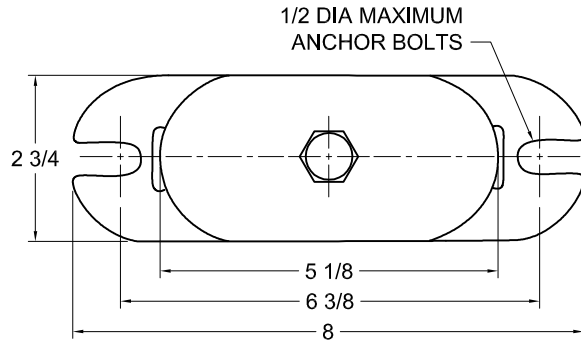

NOTES:

1. ALL DIMENSIONS ARE IN INCHES, INTERPRET PER ANSI Y14.
2. UNLESS OTHERWISE NOTED, DIMENSIONS FOR STYLE APPLY TO ALL OTHER STYLES.
3. FINISH: HOUSINGS-CAST ALUMINUM, SPRINGS-POWER COAT, HARDWARE- ZINC ELECTROPLATE.
4. REFER TO SHEET 2 OF 2 FOR INSTALLATION INSTRUCTIONS.
5. INNER SPRING (WHEN USED) NOT SHOWN.
6. ALL SPRINGS ARE DESIGNED WITH 50% OVER TRAVEL.
7. DETAILS NOT SHOWN ON OTHER VIEW FOR CLARITY.
8. RATED DEFLECTIONS ARE WITHIN 25% OF NOMINAL. HIGHER DEFLECTIONS ARE ALLOWED IF THEY MEET SPECIFICATIONS.

TYPE CALE-1D CAST ALUMINUM SPRING ISOLATORS FOR 1" NOMINAL DEFLECTION				
MODEL	MAX LOAD (LBS)	DEFLECTION (IN)	SPRING RATE (LB/IN)	SPRING COLOR CODE
CALE-1D-85	85	1.35	63	LT PURPLE
CALE-1D-120	120	1.20	100	DK YELLOW
CALE-1D-175	175	1.17	150	DK BLUE
CALE-1D-250	250	1.40	179	YELLOW
CALE-1D-340	340	1.13	300	RED
CALE-1D-510	510	1.02	500	BLACK
CALE-1D-675	675	1.32	513	DK PURPLE
CALE-1D-900	900	1.02	881	DK GREEN
CALE-1D-1200	1200	0.90	1327	GRAY
CALE-1D-1360	1360	0.77	1758	WHITE
CALE-1D-1785N ¹	1785	0.88	2029	GRAY/RED

NOTES:

1. TWO NESTED SPRINGS YIELD THIS LOAD. THE COLOR CODE IS FOR OUTER SPRING/ INNER SPRING.

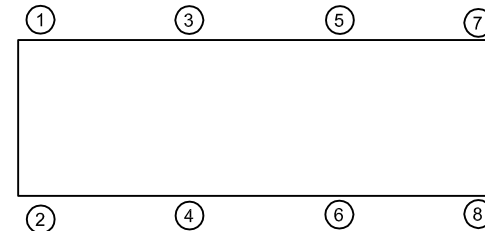

ISOLATOR SELECTIONS	
LOC 1:	LOC 2:
LOC 3:	LOC 4:
LOC 5:	LOC 6:
LOC 7:	LOC 8:
CUSTOMER EQP'T. TAG:	

NOTE: MATERIAL SHOWN IS FOR (1) SET.

OTHER MATERIALS, COMPOUNDS, OR FINISHES WITH EQUAL OR SUPERIOR PROPERTIES MAY BE SUBSTITUTED AS THEY BECOME AVAILABLE.

CERTIFIED FOR:

JOB NAME: _____
 CUSTOMER : _____
 CUSTOMER P.O.: _____
 SALES ORDER: _____

**MODEL CALE-1D 85-1785 LBS.
 ALUM. SPRING ISOLATORS SNUBBED
 WITH EXTERNAL ADJUSTMENT
 1 INCH DEFLECTION**



THE VMC GROUP
The Power of Together
 Bloomingdale, NJ 07403
 Houston, TX 77041

SCALE :
NONE
 SHEET:



DRAWING NO.: _____ REVISION

REV.	DESCRIPTION	DATE	BY

READ INSTRUCTIONS IN THEIR ENTIRETY BEFORE BEGINNING.

ALL VMC GROUP ISOLATORS ARE SHIPPED ASSEMBLED AND IDENTIFIED BY SIZE (LOAD CARRYING CAPACITY) AND BY THE COLOR CODE ON THE SPRINGS. THE NORMAL INSTALLATION AND ADJUSTMENT OF TYPE CALE ISOLATOR IS AS FOLLOWS:

- LOCATE THE ISOLATORS IN THEIR PROPER POSITION UNDER THE EQUIPMENT. SEE SUBMITTAL DATA, INSTALLATION DRAWINGS, OR OTHER CORRESPONDENCE FOR CORRECT LOCATION OF ISOLATORS WHEN DIFFERENT CAPACITY ISOLATORS ARE USED FOR UNEQUAL LOAD DISTRIBUTION. ISOLATORS SHOULD BE SET ON A FLAT, LEVEL SURFACE AT THE SAME ELEVATION. SHIMS, IF REQUIRED, SHOULD BE FULL SIZE.
- BEFORE THE ISOLATORS ARE ADJUSTED, THE WEIGHT OF THE EQUIPMENT MAY CAUSE THE TOP PLATE TO COME TO REST ON THE HOUSING. THE ISOLATORS SHOULD BE ADJUSTED TO PROVIDE A MINIMUM CLEARANCE OF 1/4" BETWEEN THE TOP PLATE AND THE HOUSING.
- INSTALL THE ADJUSTING AND LEVELING BOLTS THROUGH EQUIPMENT ISOLATING HOLES UNTIL THE BOLT COMES INTO CONTACT WITH SPRING CUP. BACK OFF THE LOCK NUT AND COMPRESS THE SPRINGS BY TURNING THE ADJUSTING BOLT "A" CLOCKWISE. START AT ONE ISOLATOR AND MAKE FOUR TURNS ON THE ADJUSTING BOLT "A", MOVE TO THE NEXT ISOLATOR AND MAKE FOUR TURNS, ETC., UNTIL ALL ISOLATORS HAVE BEEN ADJUSTED FOUR TURNS. REPEAT THIS PROCEDURE UNTIL A 1/4" GAP IS OBTAINED BETWEEN TOP PLATE AND HOUSING.
- CHECK THE LEVEL OF THE EQUIPMENT. THE EQUIPMENT MAY NOW BE LEVELED BY MAKING SMALL ADJUSTMENTS OF INDIVIDUAL ISOLATORS AT THE HIGH AND LOW POINTS.
- AFTER THE EQUIPMENT IS LEVEL, VISUALLY CHECK EACH ISOLATOR TO MAKE SURE SPRING COILS ARE NOT CLOSED SOLID AND THERE IS SUFFICIENT CLEARANCE BETWEEN TOP PLATE AND HOUSING.

NOTES:

- ALTHOUGH PROVISIONS HAVE BEEN MADE FOR ANCHOR BOLTS, THE NON-SKID ELASTOMERIC PAD ON THE BOTTOM OF THE ISOLATOR IS USUALLY SUFFICIENT TO PREVENT "WALKING" OF EQUIPMENT, AND NO BOLTING IS REQUIRED.
- IF ISOLATOR MUST BE BOLTED TO SUPPORTING STRUCTURE, BOLTS SHOULD BE HAND-TIGHT. DO NOT OVER-TIGHTEN.

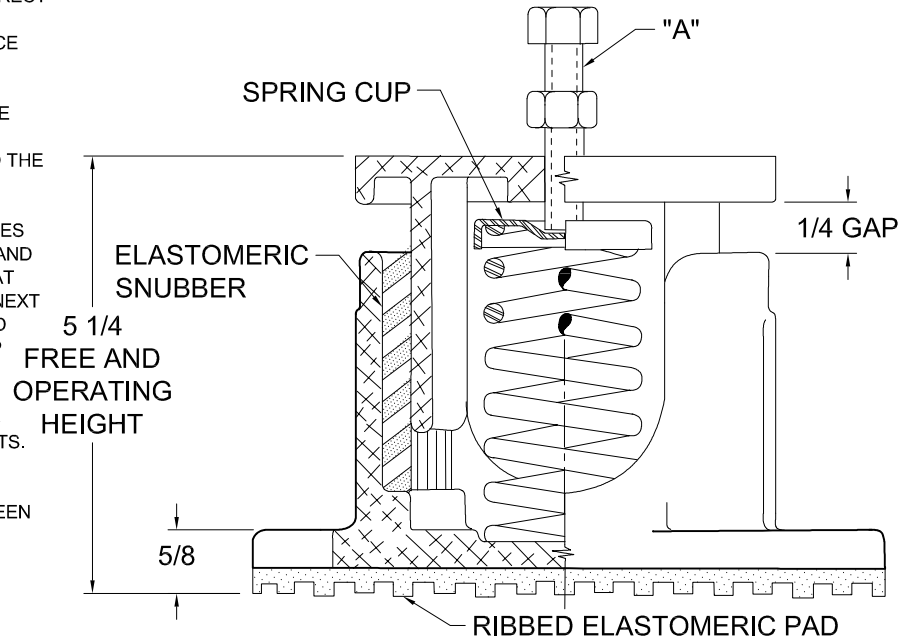

OTHER MATERIALS, COMPOUNDS, OR FINISHES WITH EQUAL OR SUPERIOR PROPERTIES MAY BE SUBSTITUTED AS THEY BECOME AVAILABLE.

CERTIFIED FOR:

JOB NAME: _____
 CUSTOMER: _____
 CUSTOMER P.O.: _____
 SALES ORDER: _____

**MODEL CALE-1D 85-1785 LBS.
 ALUM. SPRING ISOLATORS SNUBBED
 WITH EXTERNAL ADJUSTMENT
 1 INCH DEFLECTION**



THE VMC GROUP
The Power of Together
 Bloomingdale, NJ 07403
 Houston, TX 77041

SCALE: NONE
 SHEET: _____



DRAWING NO.: _____ REVISION: _____